

Leclerc Looms

Since 1876



1573 Savoie
C. P. 4 Plessisville, Qc.
G6L 2Y6
TEL: 819-362-7207
FAX: 819-362-2045
www.leclerclooms.com
info@leclerclooms.com

ARTISAT 36" JACK- TYPE 4 shaft loom 1009-0000



On receiving the loom,
unpack and lay out the loom
components.
Do NOT discard any packing
material until all parts are
inventoried.

Check the parts received
against the parts list on pages #2 to
#5 of the assembly instructions.
Report any discrepancies to Leclerc
immediately.

To assemble this loom, a
minimum of 2 people are
needed but it is recommended
you use 3.

Loom Prepared by: _____

Inspected by: _____

Date: _____

Artisat/4s.afpub (2026)

PARTS LIST

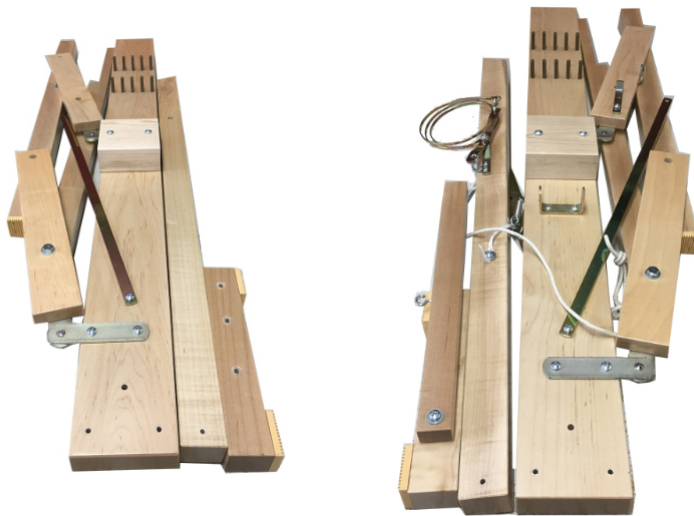

Note for Leclerc in French:

Trous de bout avec mèche 3/16"

Corde de frein en corde de coton 31"

LEFT-HAND SIDE

with base packed separately

1 RIGHT-HAND SIDE

with base and brake treadle packed separately

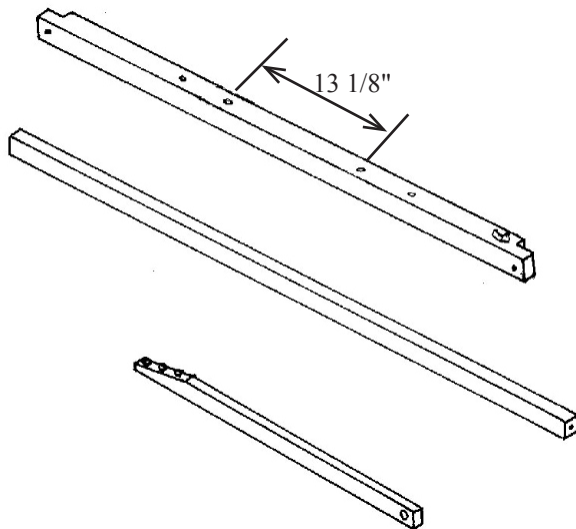

1 FRONT CROSS-MEMBER

1 MIDDLE LOWER CROSS-MEMBER

6 TREADLES



1 TREADLE ROD 14 1/2" with one push nut



1 MORE PUSH NUT 7/16"

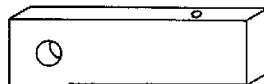

2 TREADLE set SUPPORTS

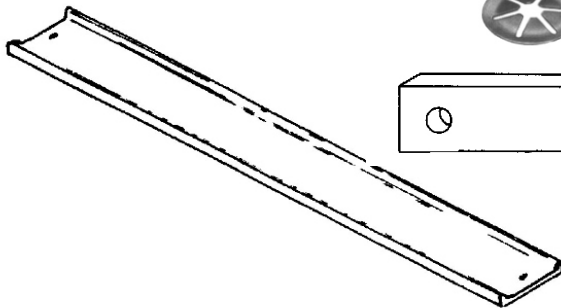

1 Castle top cover (shelf)

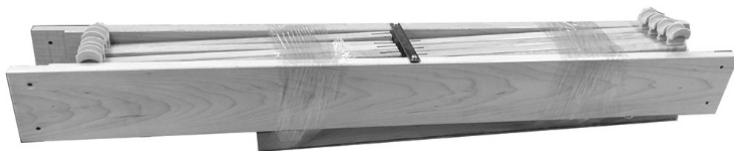

1 Jack box with 4 lams clip to the jacks

Note for Leclerc in French:
Nouveau pare-choc sous son-tremarche en 2026.



1 PK. 10 YDS FOR BEAM STICK
 1 PK 5 YDS FOR BEAMING AND LEASE
 STICK

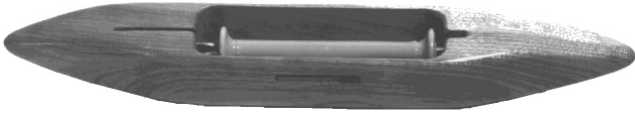

1 SHUTTLE



1 DOZ. BOBINES 4"

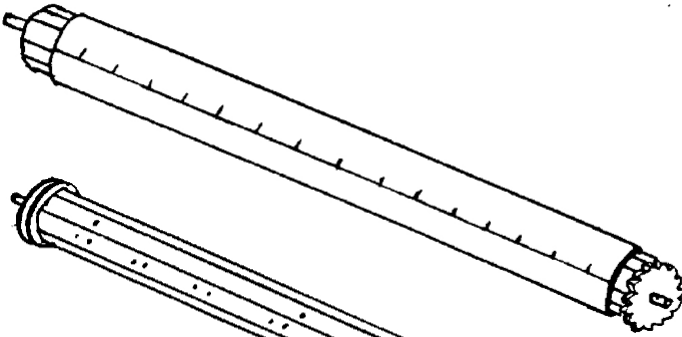

1 CLOTH BEAM WITH RATCHET
 WHEEL (wood = 38 1/8")

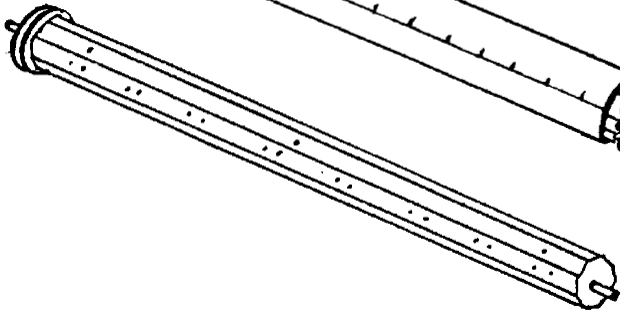

1 WARP BEAM WITH BRAKE DRUM
 (wood = 38 7/8")

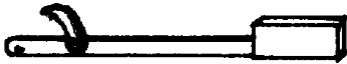

1 TAKE-UP MOTION HANDLE

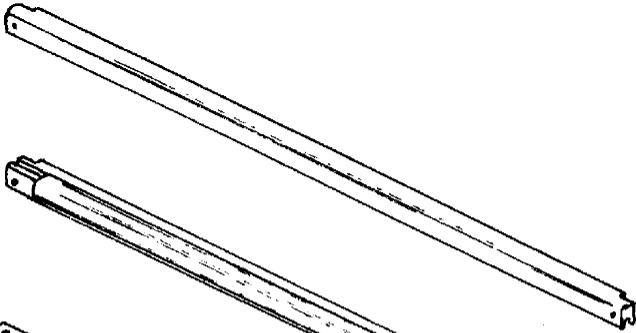

1 BATTEN HANDTREE

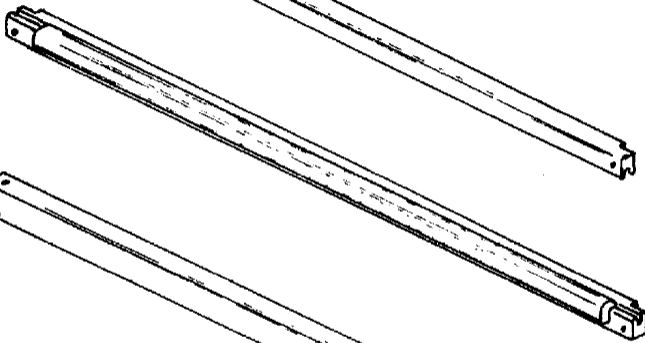

1 BATTEN SLEY WITH SHUTTLE RACE

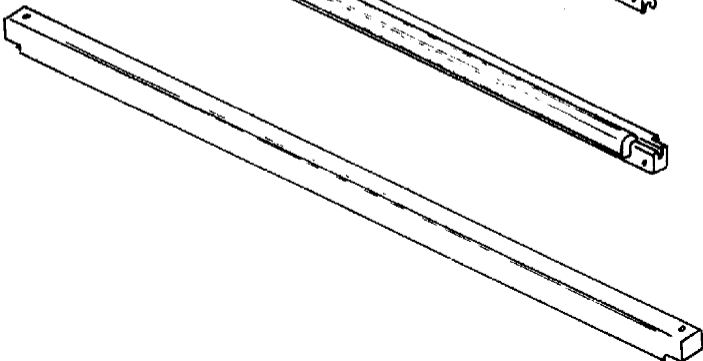

2 BREAST BEAMS

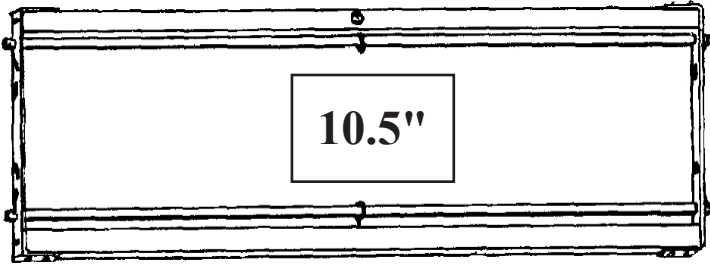

4 SHAFT (harness) FRAMES

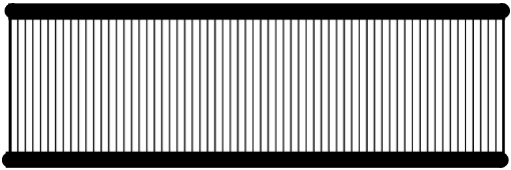

1 REED



2 LEASE STICKS



1 BEAM STICKS



3 WARP RODS



10.5"

1000 HEDDLES



1 HEDDLE AND REED HOOK



1 Black Screwdriver



1 Adjustment wrench

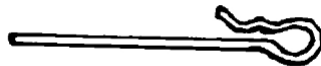

6 TREADLE HOOK 7" LONG



12 TREADLE CORDS 7"

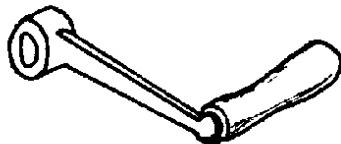

1 CRANK FOR BACK BEAM

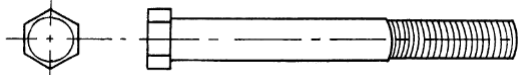



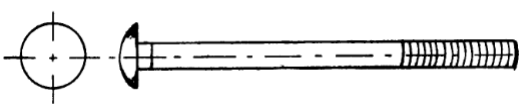



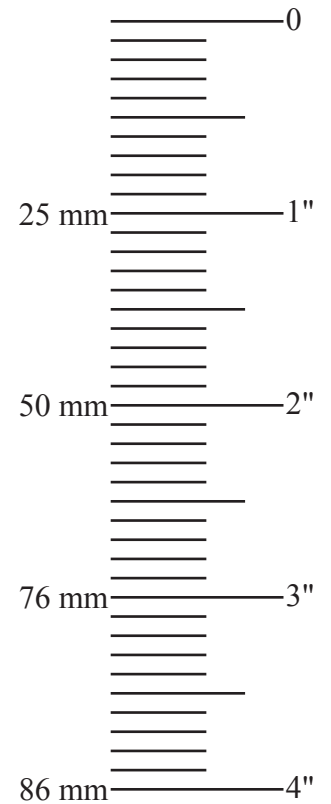

Machine bolts
 1 X 7/16 X 3 1/2"
 1 X 1/4" X 4" (lams)



Carriage Bolts
 2 - 1/4" X 3 1/2" (Front Cross-Member)
 2 - 1/4" X 3" (Treadle blocs)
 2 - 1/4" X 1 3/4"
 4 - 5/16 X 2 1/2"



	4 - 1/4" 3 - 9/16" 4 - 5/16"
	Wing nuts 4 X - 1/4" 2 X - 5/16"
	Square nuts 2 X 5/16"
	3 X Autolock Nuts 1/4"
	3 X Nylon Spacers
	2 X Nylon Washers
	Round head screw 4 X #14 X 2" 8 X #12, 1 1/2" 8 X #14, 2 1/2"
	Flat head screw 2 X #12 X 1 1/2" (castle top)
	2 X eye screws

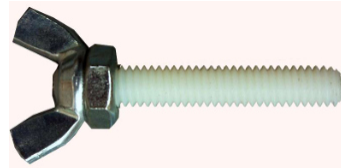

Nylon Wing nut for the Warp beam advance control system

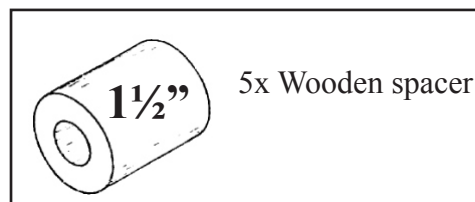

Instruction video.
 In case of difference between the video and the instruction, follow the written instruction.
<https://vimeo.com/589468315/08fb1136ed>



Back board protection plate

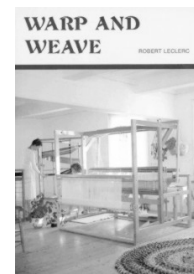

1 book
 Warp &
 Weave

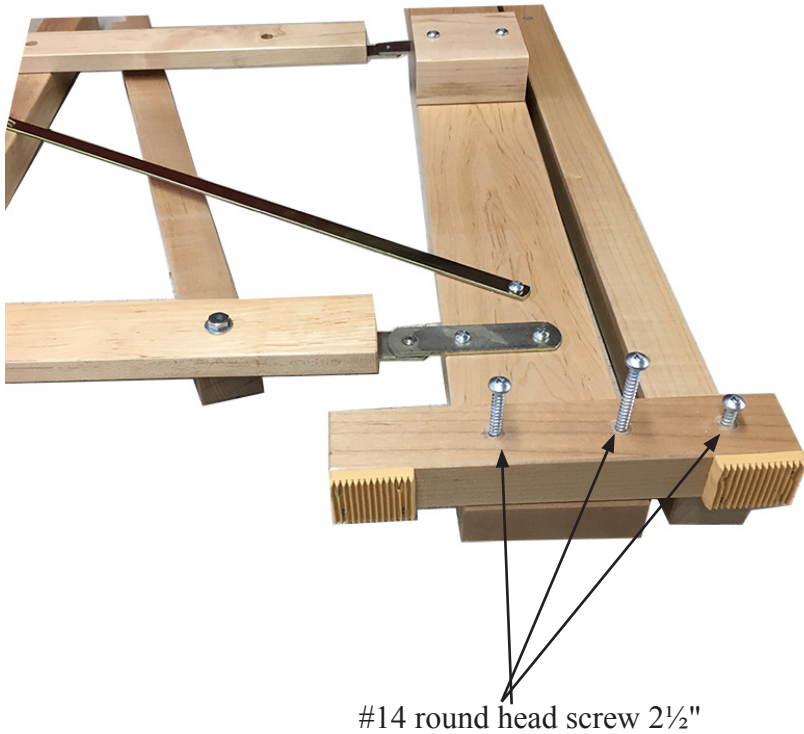

#14 round head screw 2½"

Lay the left side on the floor with caution (you can put a piece of cardboard on the floor). Remove the packing material and using three #14 round head screw 2½", affix the base to the left upright and the back post to the base.

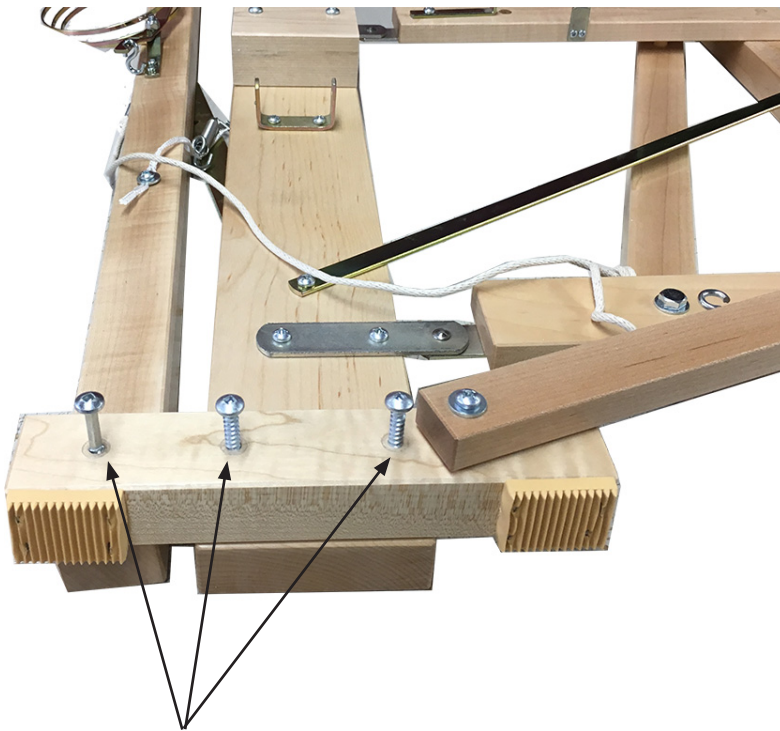

#14 round head screw 2½"

Lay the right side on the floor with caution (you can put a piece of cardboard on the floor). Remove the packing material and using three #14 round head screw 2½", affix the base (the brake treadle is already installed) to the right upright and the back post to the base.

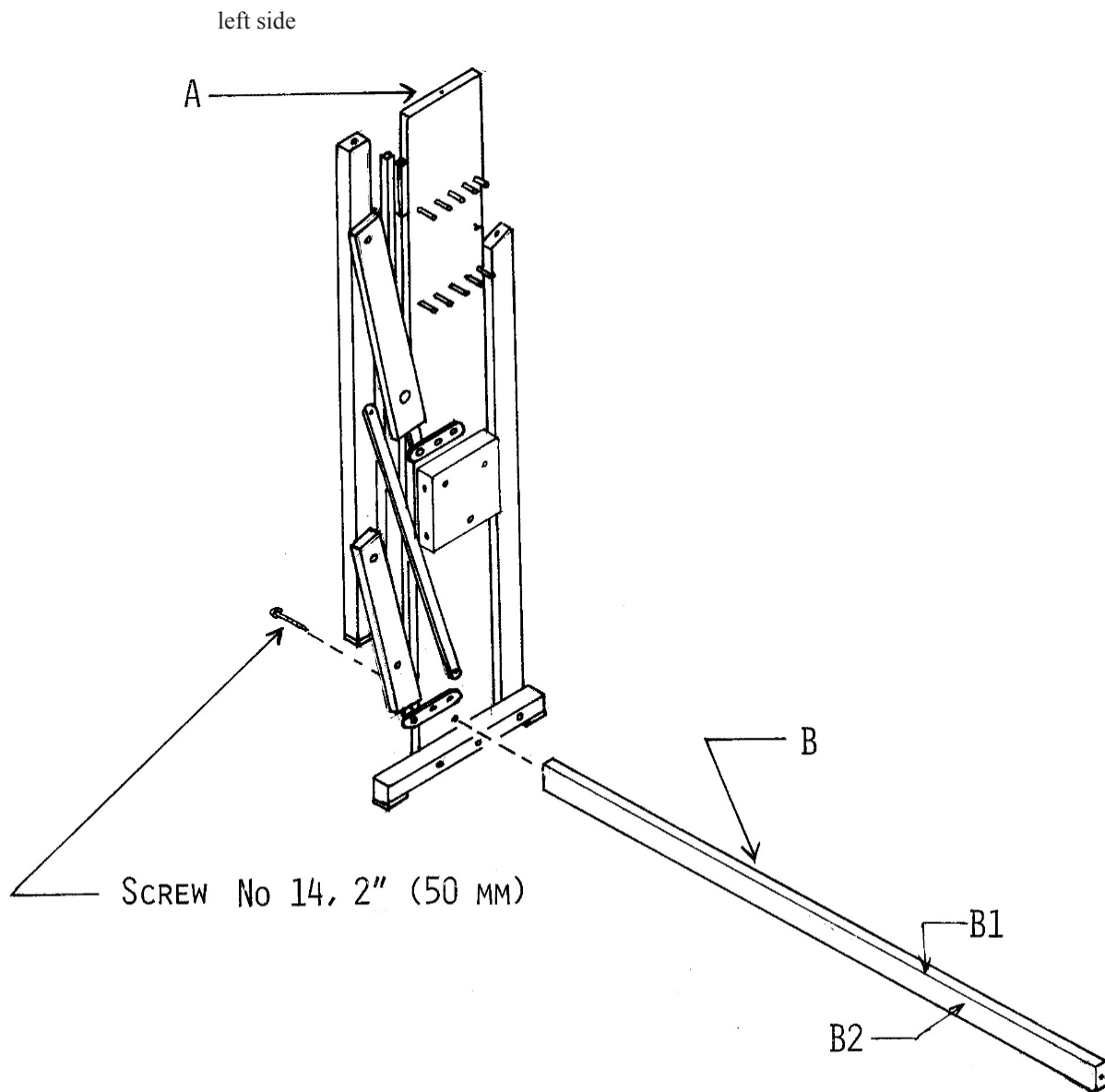

Using a 2" (50-mm) round-headed screw no 14, affix lower middle cross-member B to the bottom of left-hand side A.
The lower middle cross-member has a hole at either end; the narrow sides B1 must be above and under the cross-member and the wide faces B2 must be on the sides.

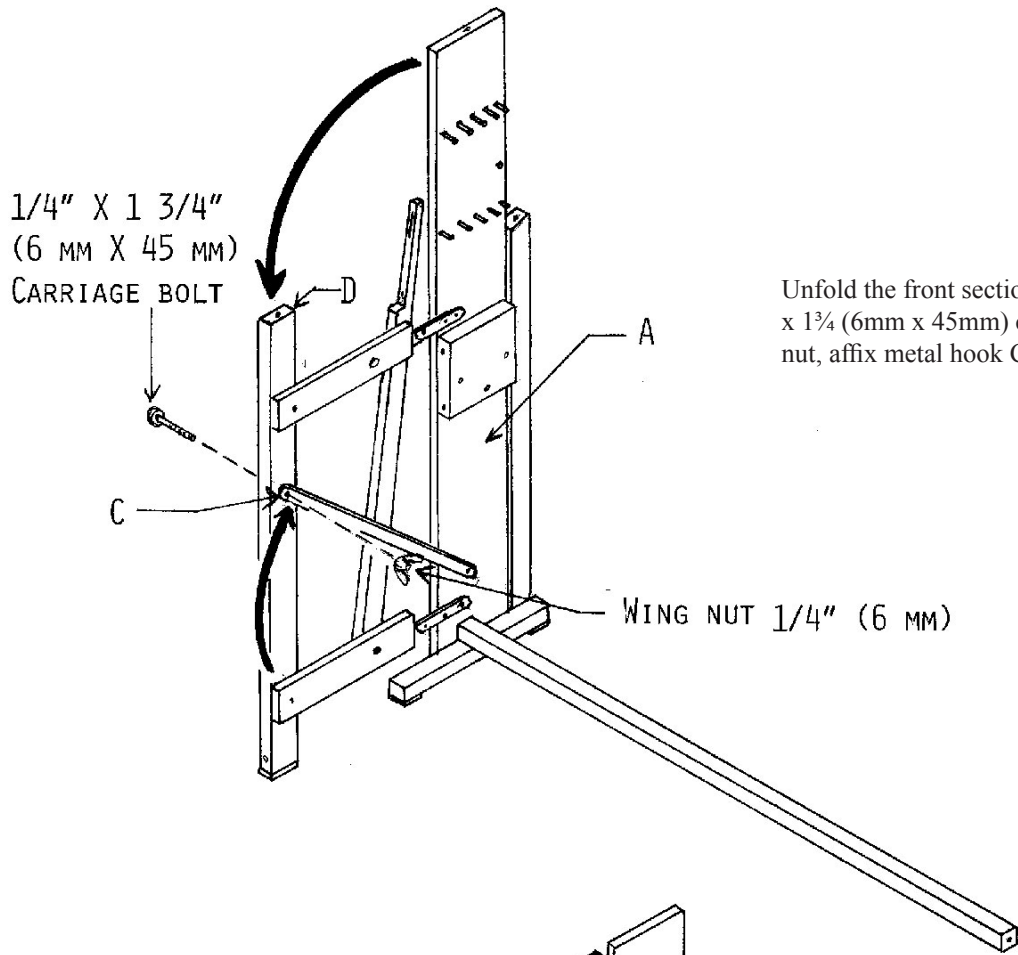

1/4" X 1 3/4"
(6 MM X 45 MM)
CARRIAGE BOLT

Unfold the front section of left-hand side A. Using a 1/4" x 1 3/4" (6mm x 45mm) carriage bolt and a 1/4" (6mm) wing nut, affix metal hook C to left-hand side front post D.

WING NUT 1/4" (6 MM)

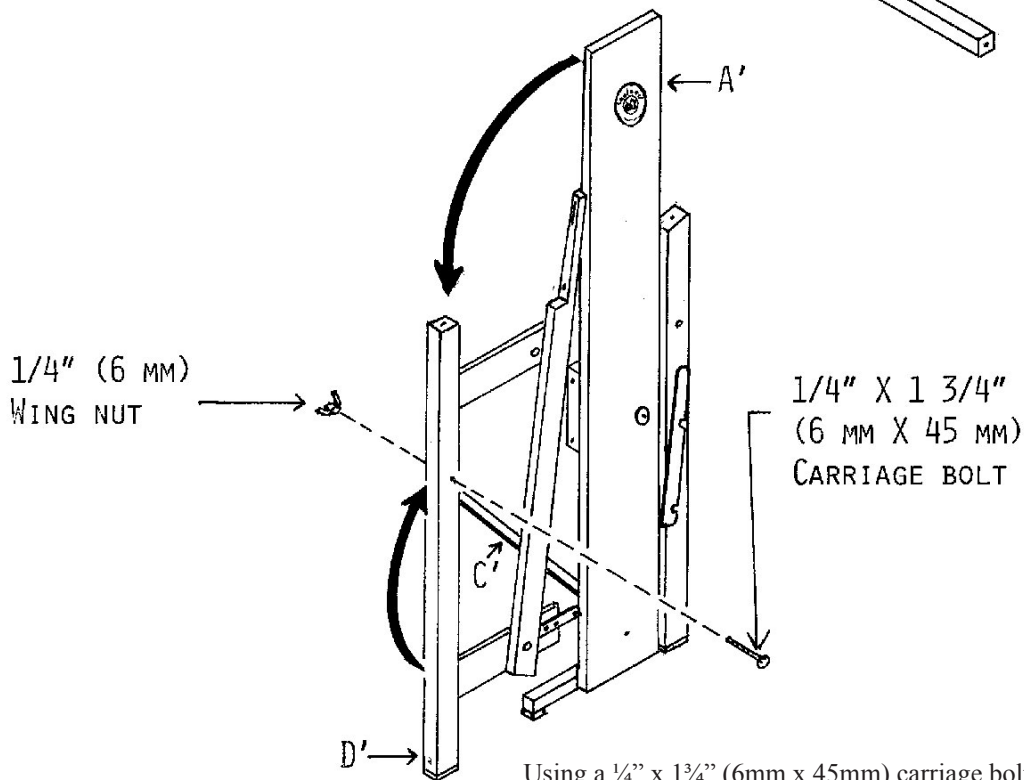

1/4" (6 MM)
WING NUT

1/4" X 1 3/4"
(6 MM X 45 MM)
CARRIAGE BOLT

Using a 1/4" x 1 3/4" (6mm x 45mm) carriage bolt and a 1/4" (6mm) wing nut, affix metal hook C' to right-hand side front post D'.

Place the take-up motion handle E, with a 9/16" steel washer, on the right-hand side end of cloth beam F.

Note: The ratchet gear is on the right-hand side beam end.
The ratchet pawl affixed to the take-up motion handle must be lifted up.

Insert the end of cloth beam F into the holes in upper front cross-members G and G'. The hole in lower middle cross-member B must be right beside the hole at the bottom of right-hand side A'.

Using a 2" (50 mm) round-headed screw no. 14, affix right-hand side A' to lower middle cross-member B.

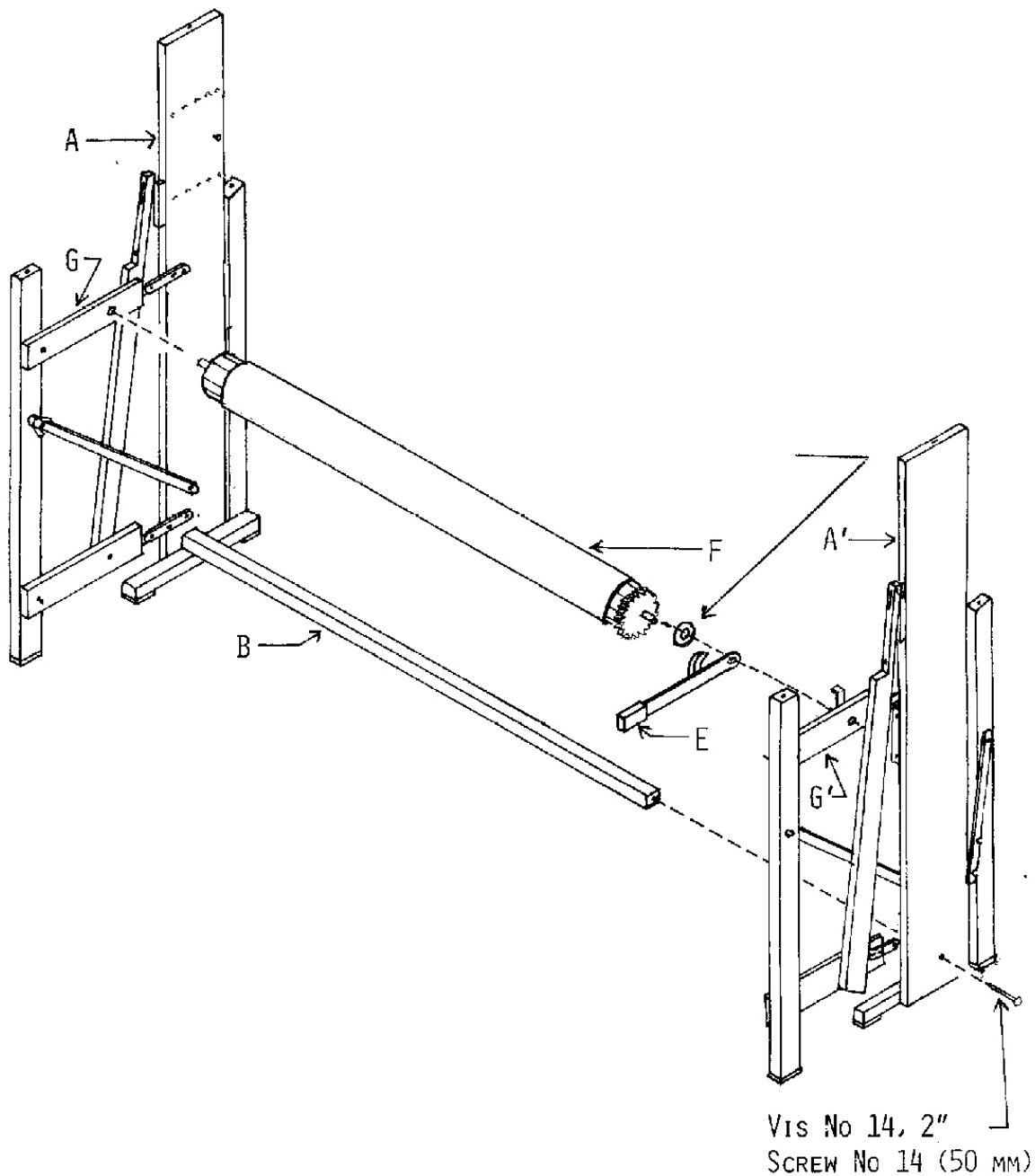

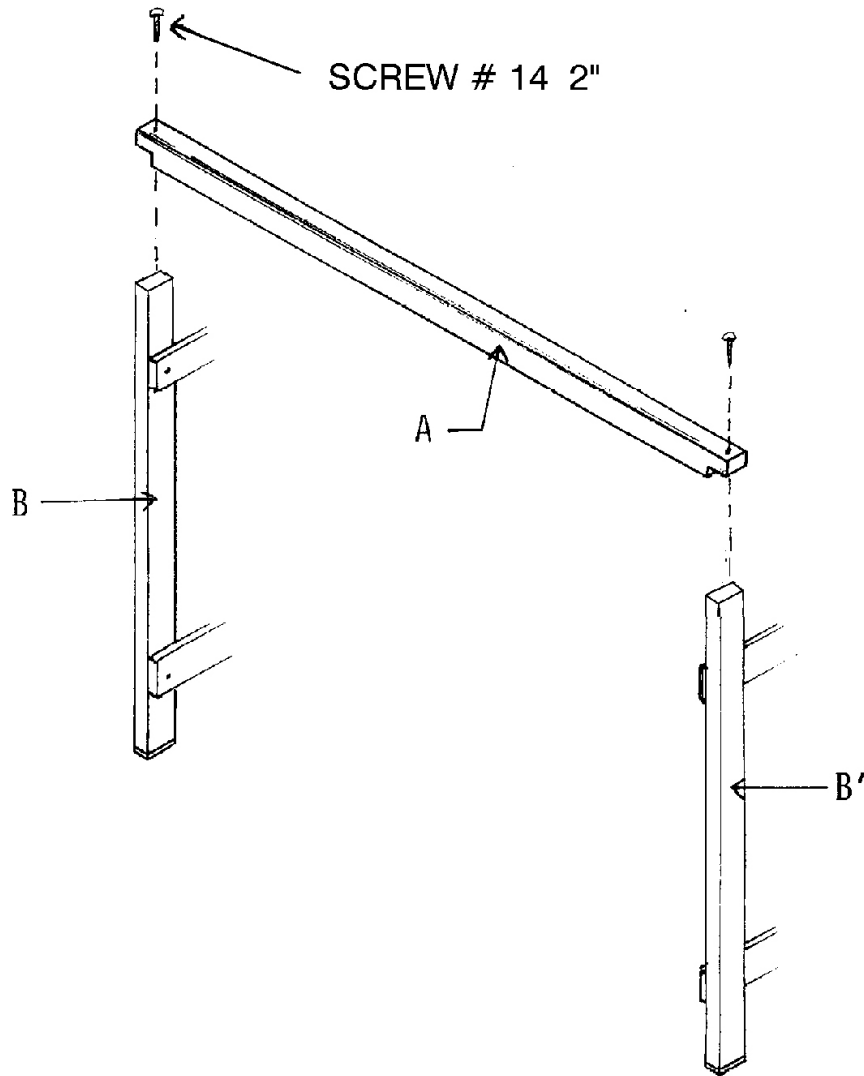

Using two 2" (50 mm) round-headed screws no. 14, affix one of the two breast beams to the top of the front posts B and B`

The rounded edge must be towards the outside of the loom.

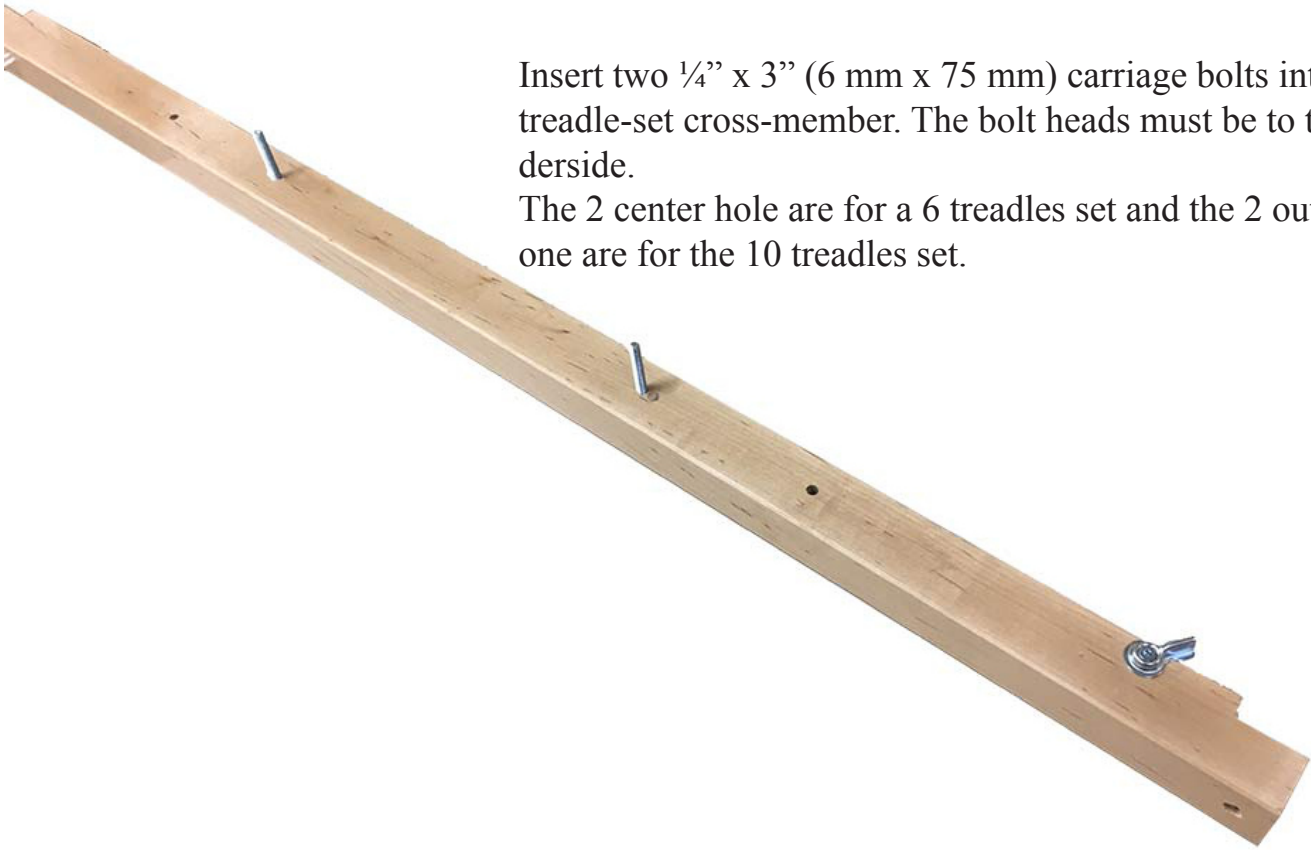

Insert two $\frac{1}{4}$ " x 3" (6 mm x 75 mm) carriage bolts into the treadle-set cross-member. The bolt heads must be to the underside.

The 2 center hole are for a 6 treadles set and the 2 outside one are for the 10 treadles set.



Using two $\frac{1}{4}$ " x $3\frac{1}{2}$ " carriage bolts, two $\frac{1}{4}$ " steel washers and two octagonal autolock nuts, attach front cross-member to front posts.

Insert to the treadle rod (with push nut)

1 Treadle support

One Washer 9/16"

One treadle and one treadle spacer 5 times (9 times for the 8s loom)

One treadle,

One Washer 9/16"

1 Treadle support

And one Push nut.

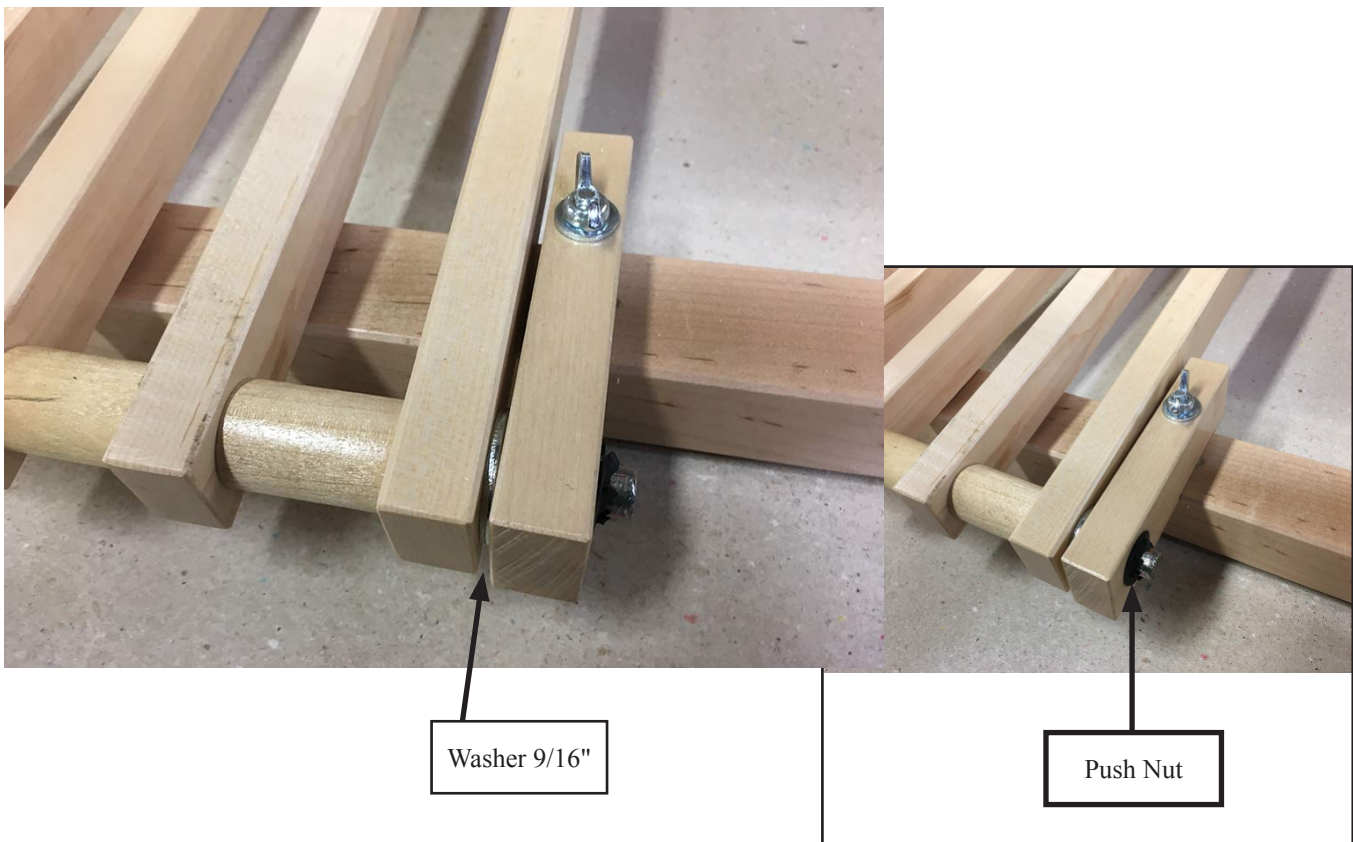

Affix the treadle set to the front cross-member using two washers $\frac{1}{4}$ " and two wing nuts $\frac{1}{4}$ ".

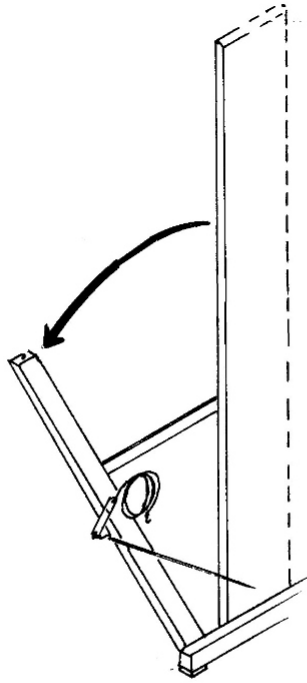

Unfold the back portion of the loom and lock it there with metal hook A

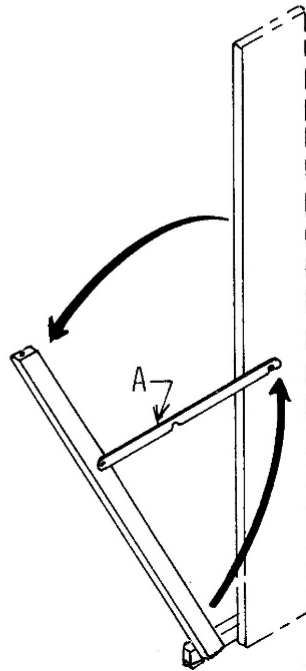

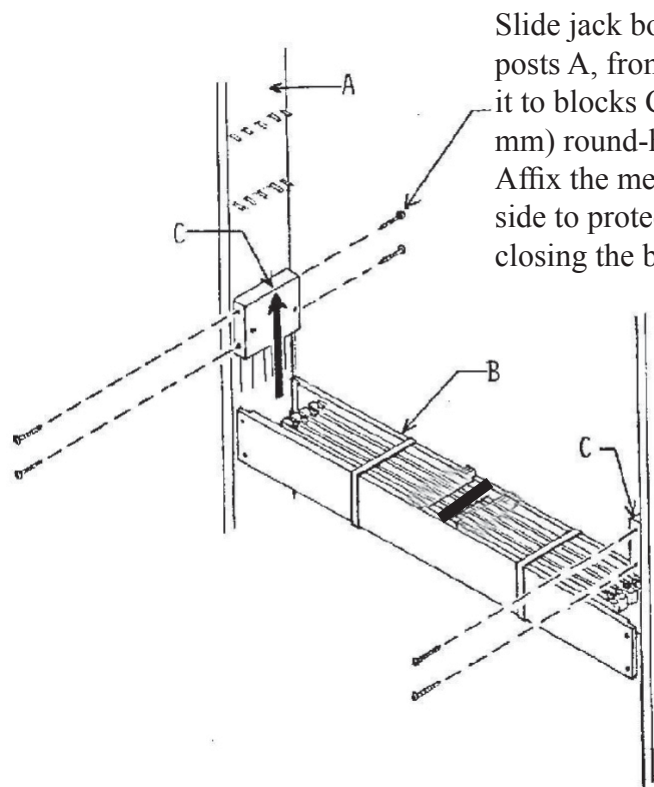

Slide jack box B along the middle posts A, from bottom to top, and affix it to blocks C using eight 1½" (40 mm) round-headed screws no. 12. Affix the metal plate at the brake side to protect the back board when closing the back of the loom.

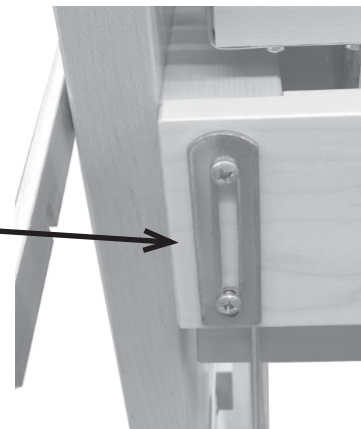

Install the heddles in the shaft frames. (see "WARP AND WEAVE" on page 10)

Remove the saran wrap on the jack box.

Slide shaft frames T between dividers Q. The shaft frames must rest on the plastic supports U of the jacks

NOTE: Some shafts may be tight between the castle frame until the castle top is attached

The Leclerc Logo goes in the top front of each shaft frame

The **double** ratchet pawl Q affixed to the Side Loom must be lifted up while inserting the Jack Box.

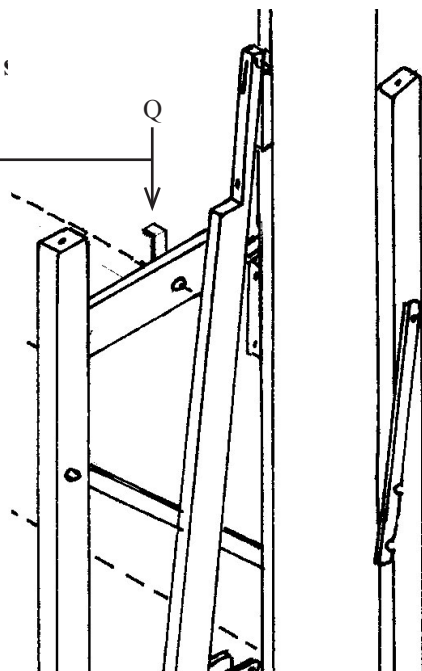
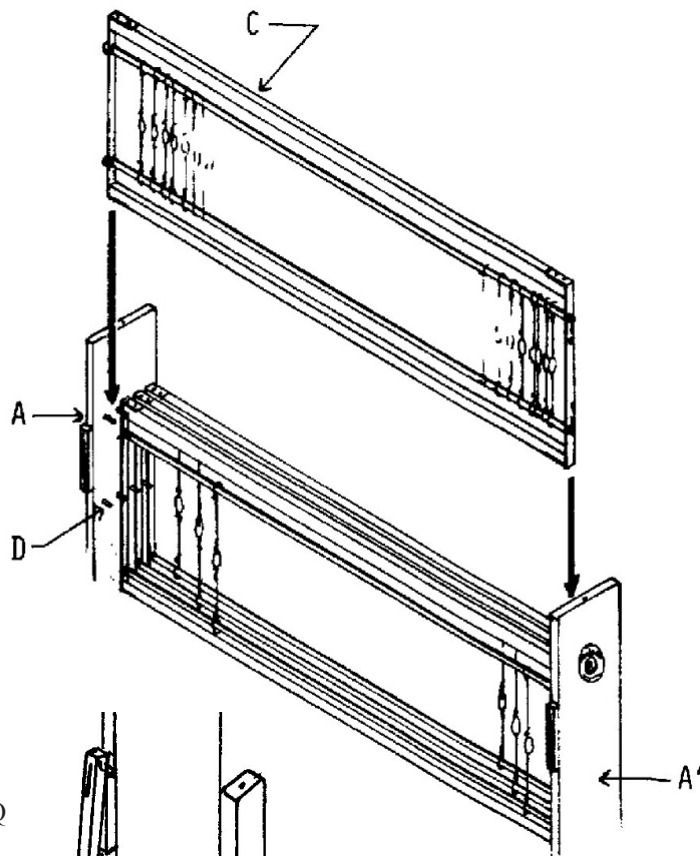

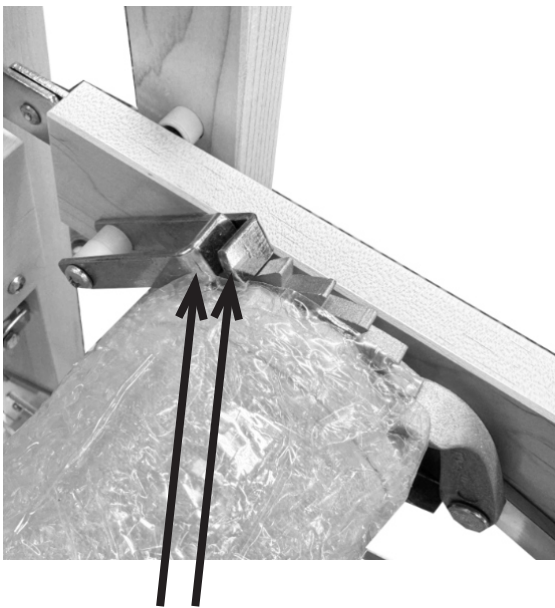

Double Ratchet Pawls

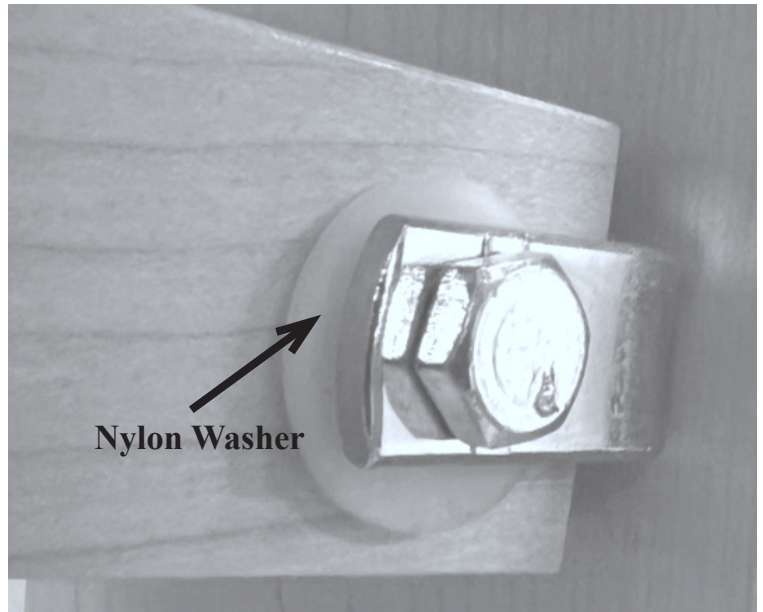

Nylon Washer

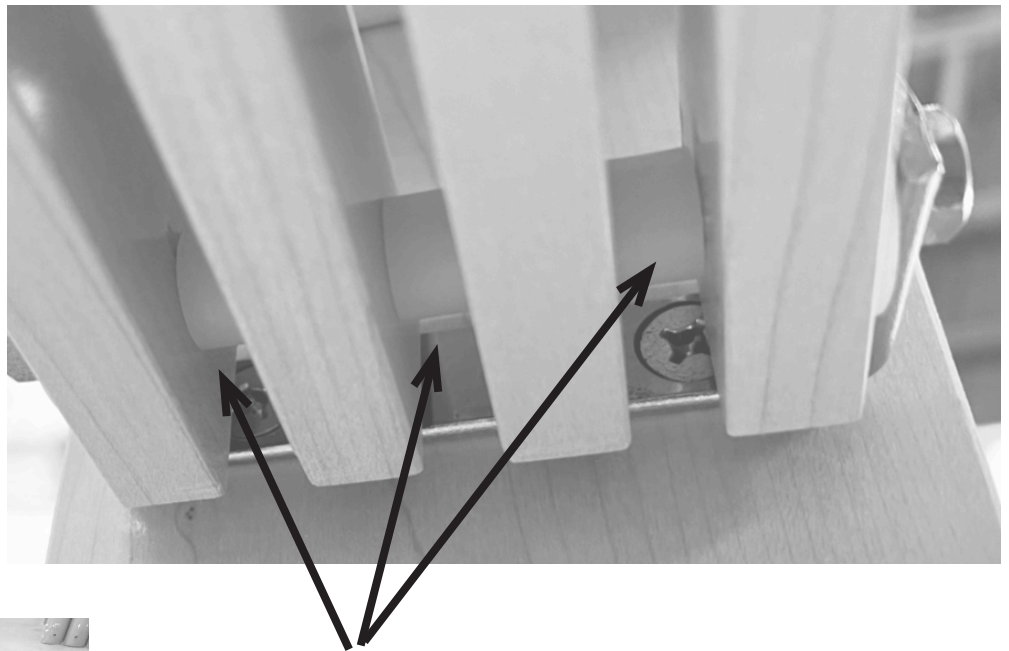

Nylon Spacers



Using a 1/4" x 4" machine bolt and one 1/4" octagonal nut, affix the four lams to the metal lam support of right-hand side main post.

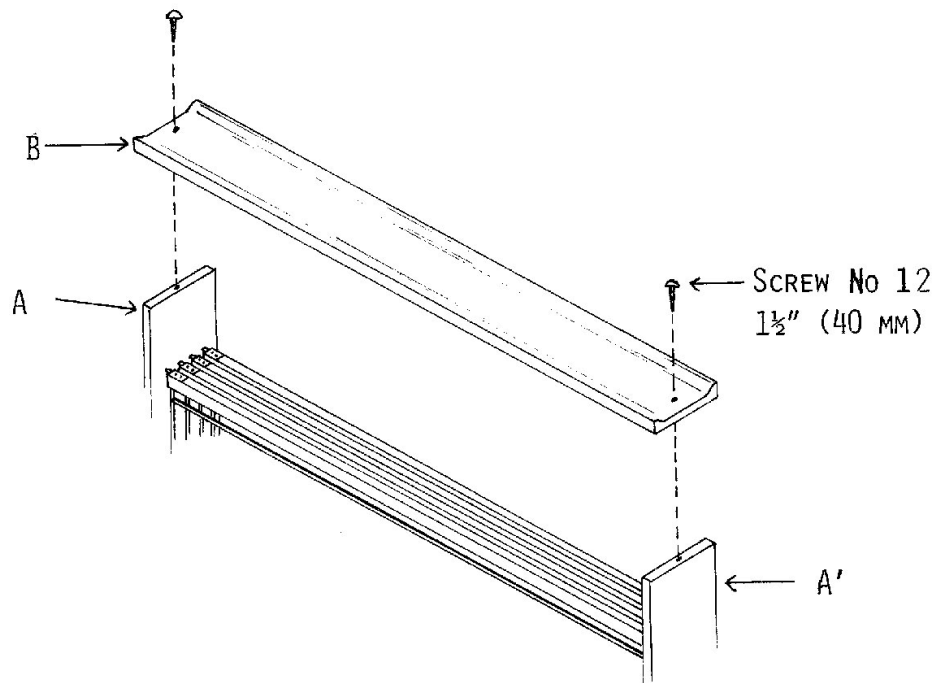

Castle cover

Complete the assembly with securing the Castle cover with 4 #12 1½" flat screws.

IMPORTANT:

Make sure to screw into the pre-drilled holes of the castle.

Wing nut 5/16" (8 mm)

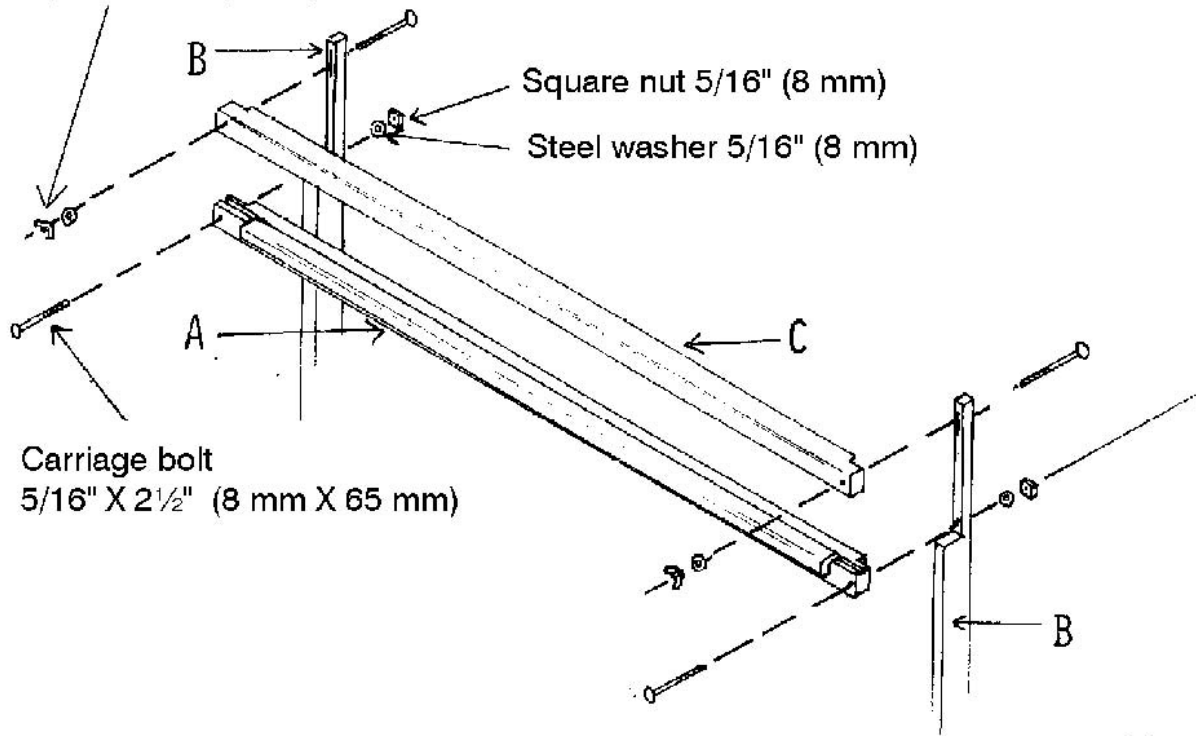

Square nut 5/16" (8 mm)

Steel washer 5/16" (8 mm)

Carriage bolt
5/16" X 2 1/2" (8 mm X 65 mm)

Install the treadle cords with the treadle hooks.

Using the carriage bolts, steel washers and square nuts, attach the batten sley A (with shuttle race) to the batten swords B.

Then affix the batten handtree C to the batten swords B.

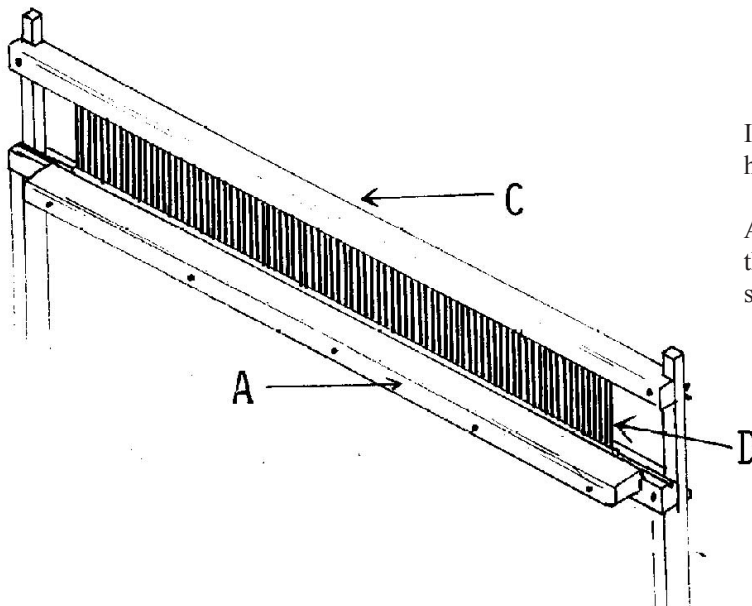

Install reed D in the slots of batten handtree C and batten sley A.

Adjust batten handtree C by sliding the bolts in the slots of the batten swords to firmly hold the reed.

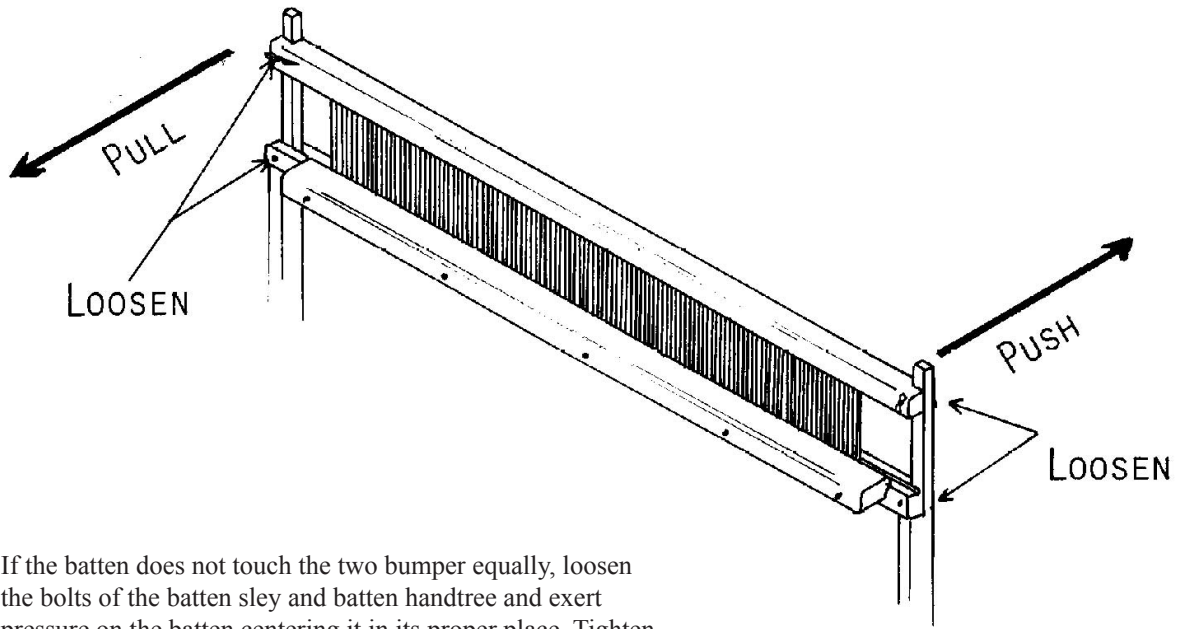

If the batten does not touch the two bumper equally, loosen the bolts of the batten sley and batten handtree and exert pressure on the batten centering it in its proper place. Tighten the bolts again.

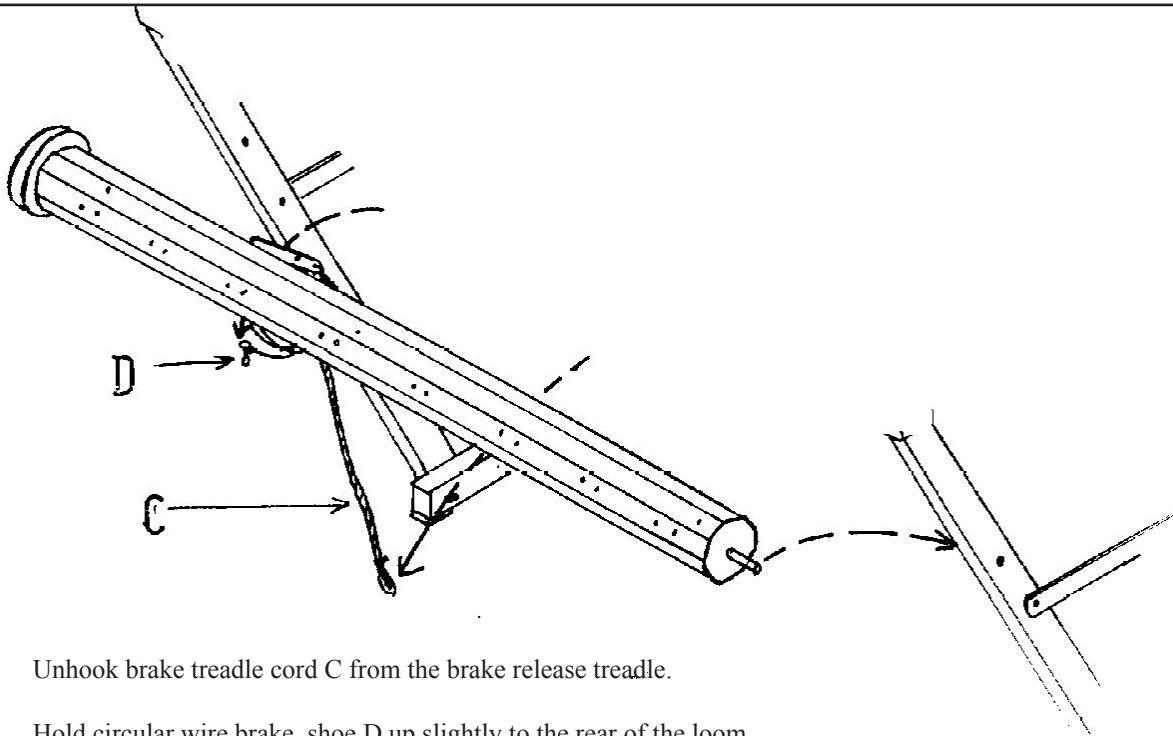

Unhook brake treadle cord C from the brake release treadle.

Hold circular wire brake shoe D up slightly to the rear of the loom.

Insert one end of the warp beam (which has only a metal post) into the left-hand side back post.

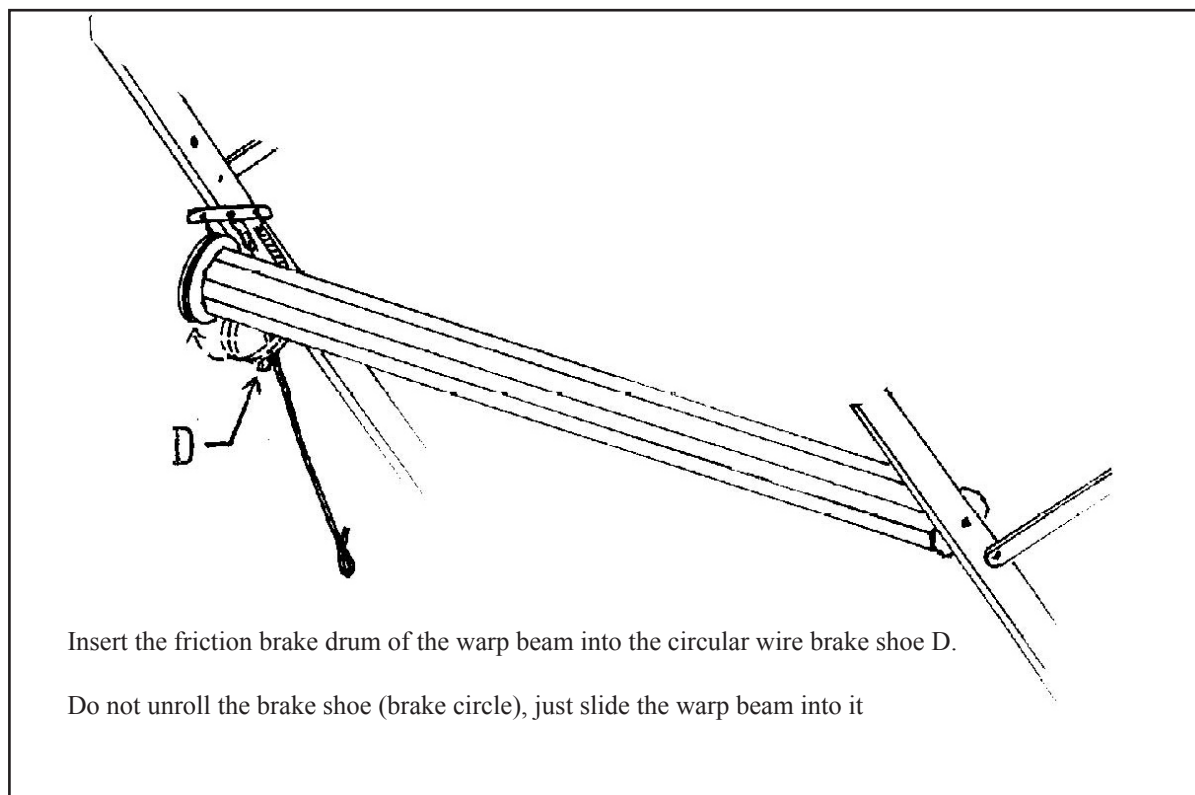

Insert the friction brake drum of the warp beam into the circular wire brake shoe D.

Do not unroll the brake shoe (brake circle), just slide the warp beam into it

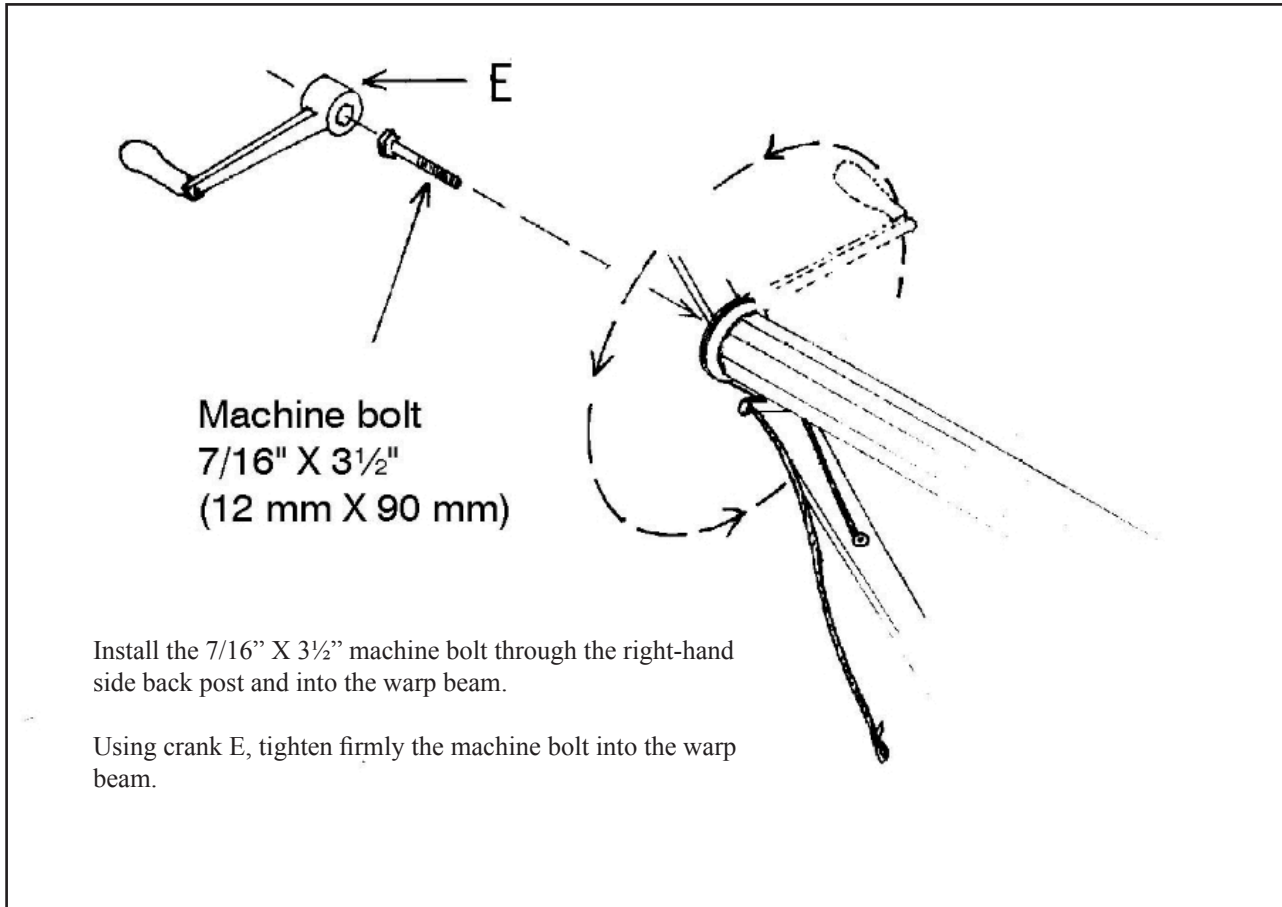
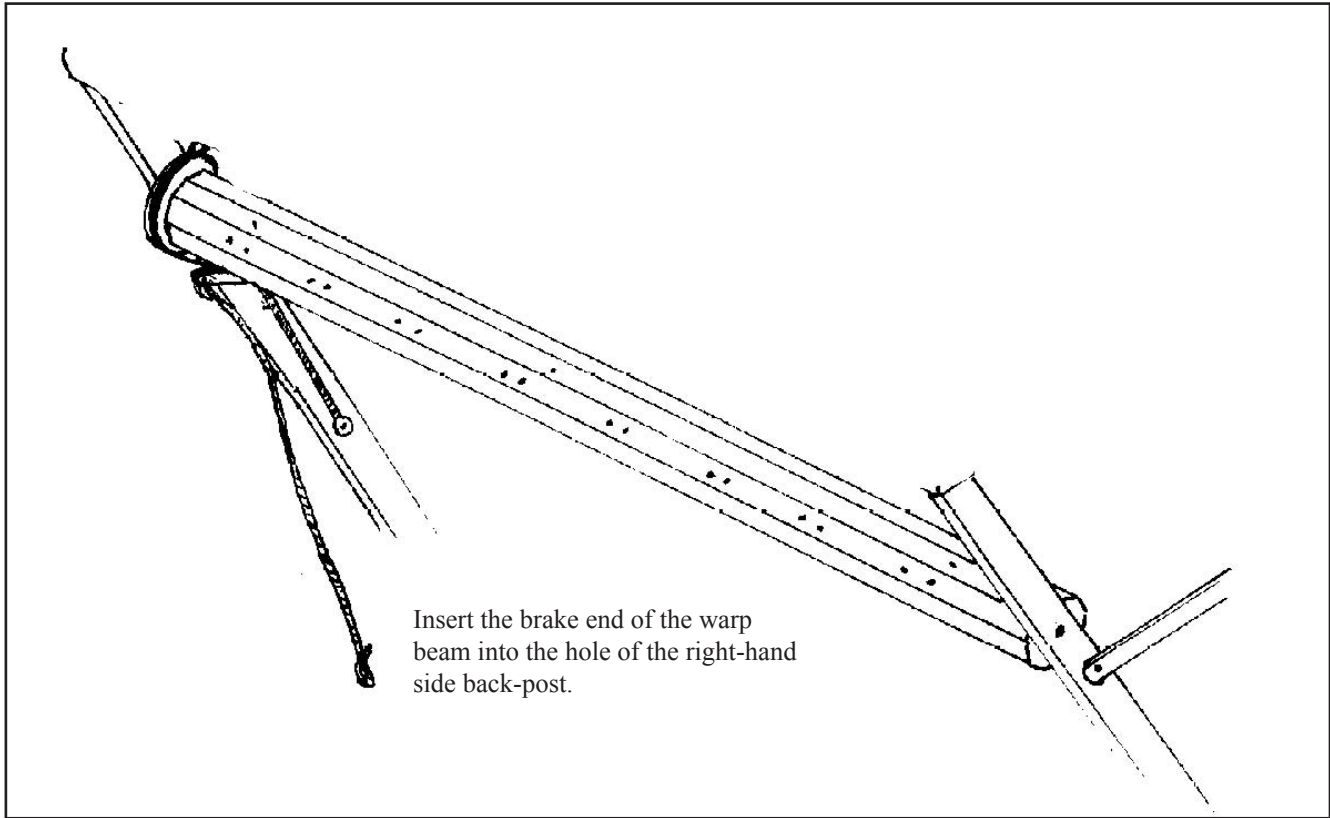

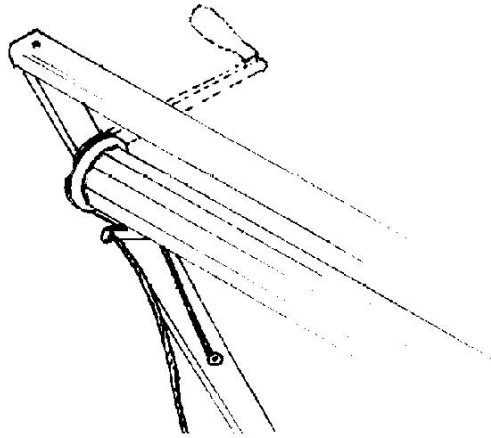

Using two 2” round-headed screws no 14, affix the breast back beam to the back posts.

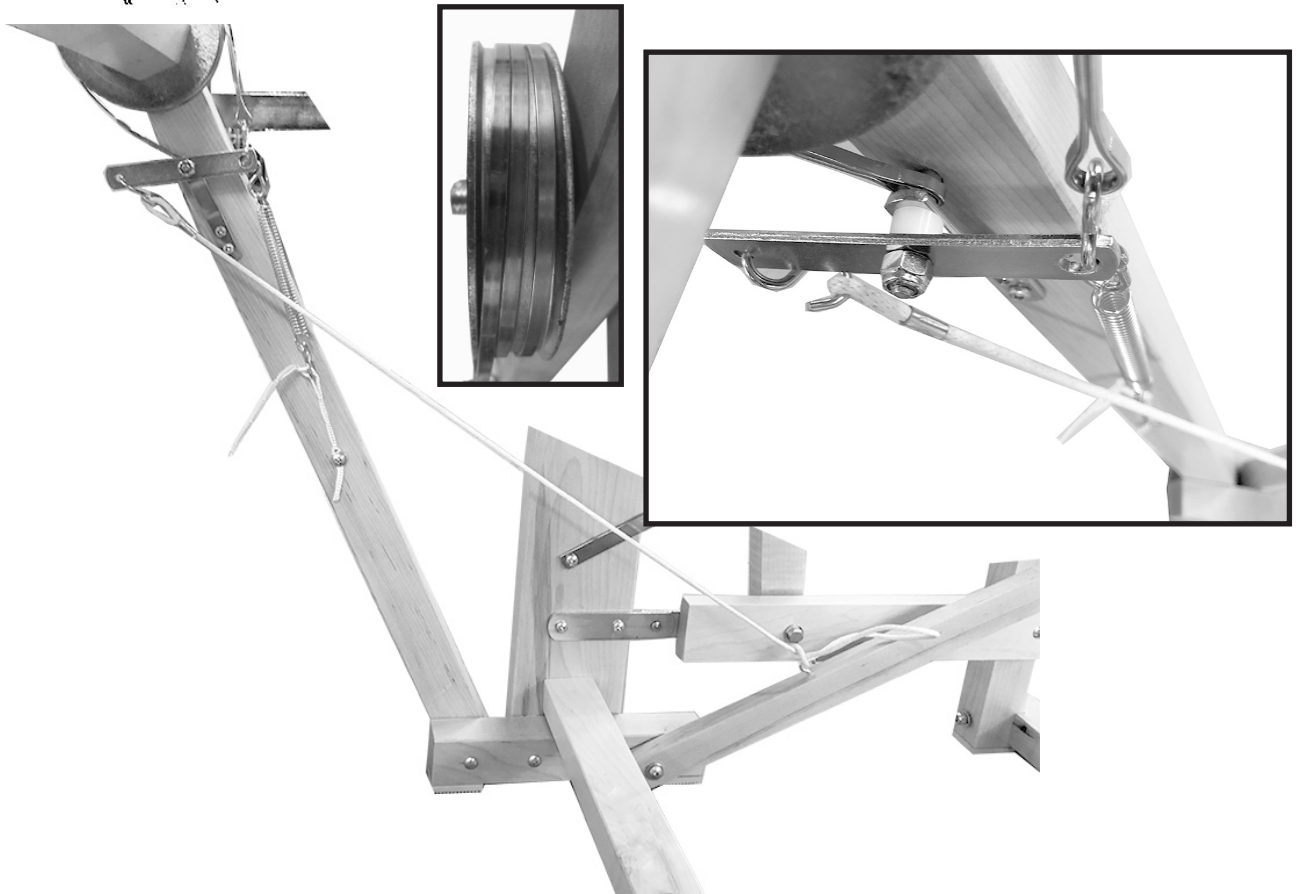

See this short video: <https://vimeo.com/893876735/bb309f2392>

Join the front “S” hook of the brake lever to the brake loop cord so the tension on the spring will be high enough to lock the warp beam while weaving.

The warp beam should turn with some friction clockwise (while standing at the right side of the loom near the brake system) and this is the warping rotation. However, you should always release the tension on the friction brake system by disconnecting the spring from the loop cord (S hook) when you are warping the loom.

To advance the fabric when weaving, depress the brake treadle just enough to release the warp beam. Depressing the brake treadle too far may cause the brake circle to come off the brake drum.

Join the brake treadle to the S Hook in the back of the Brake Lever. Adjust the length so the brake treadle is at a comfortable height. Make a double knot at the brake treadle eye.

New control advance system:

This system will eliminate excessive warp yarn advance when releasing the brake system at cloth take-up.

This friction system is adjustable and have to be released when winding the warp on. Just screw in the wing screw to increase the friction or unscrew it to release.

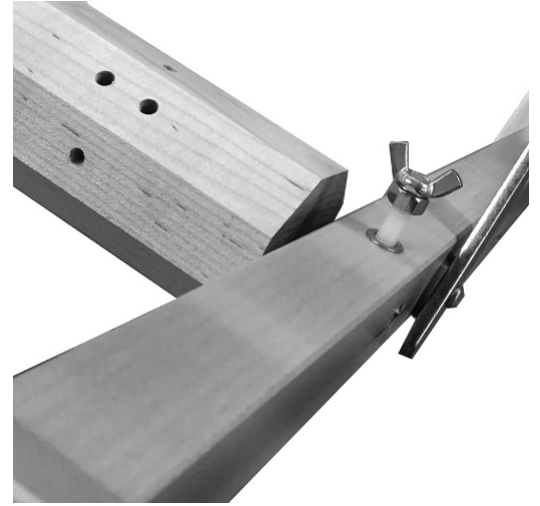

Using two 2" round-headed screws no 14, affix the FRONT breast beam to the FRONT posts.

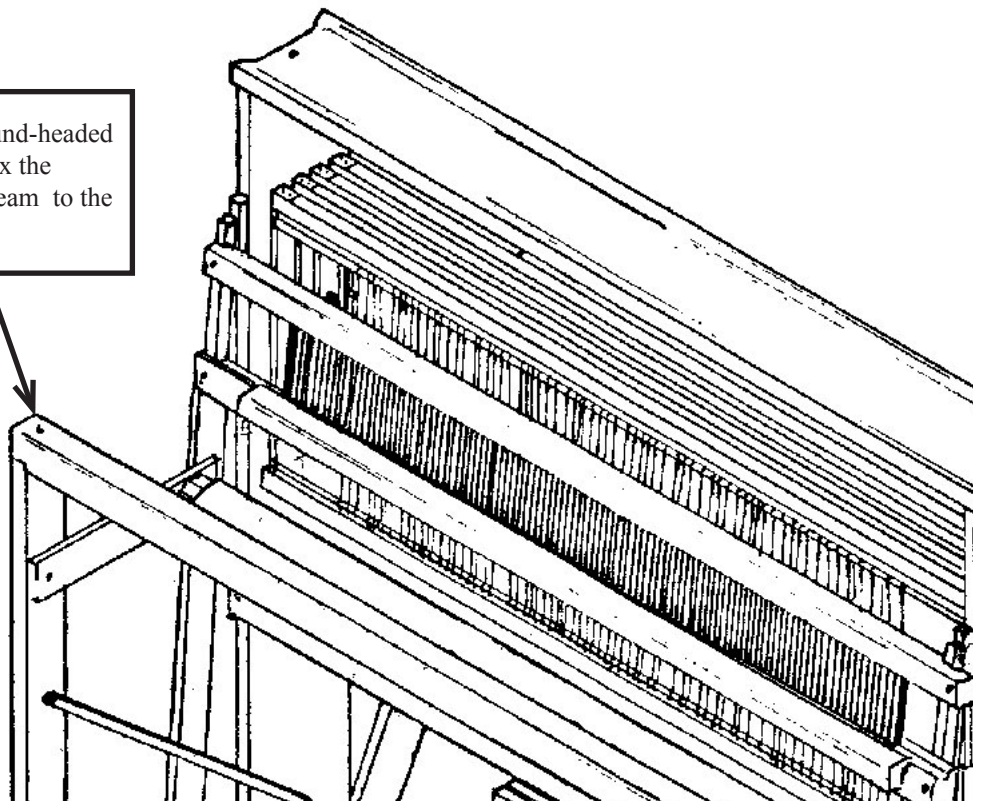

FIRST TREADLE TIE-UP

Select any treadle and tie the Lams to the Treadles using the 7" cords supplied with the loom. Take the threading hook to help pass the cord through each hole of the lam.

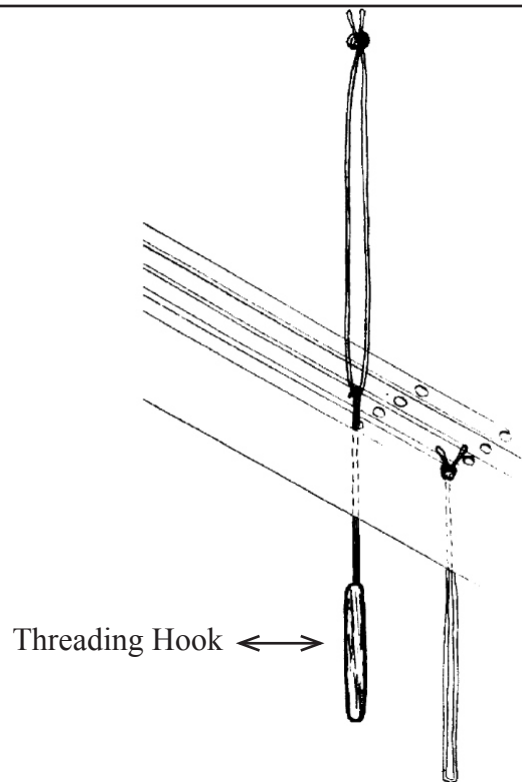

Slide the Treadle Hook through the Screw Eyes and Cord Loops.

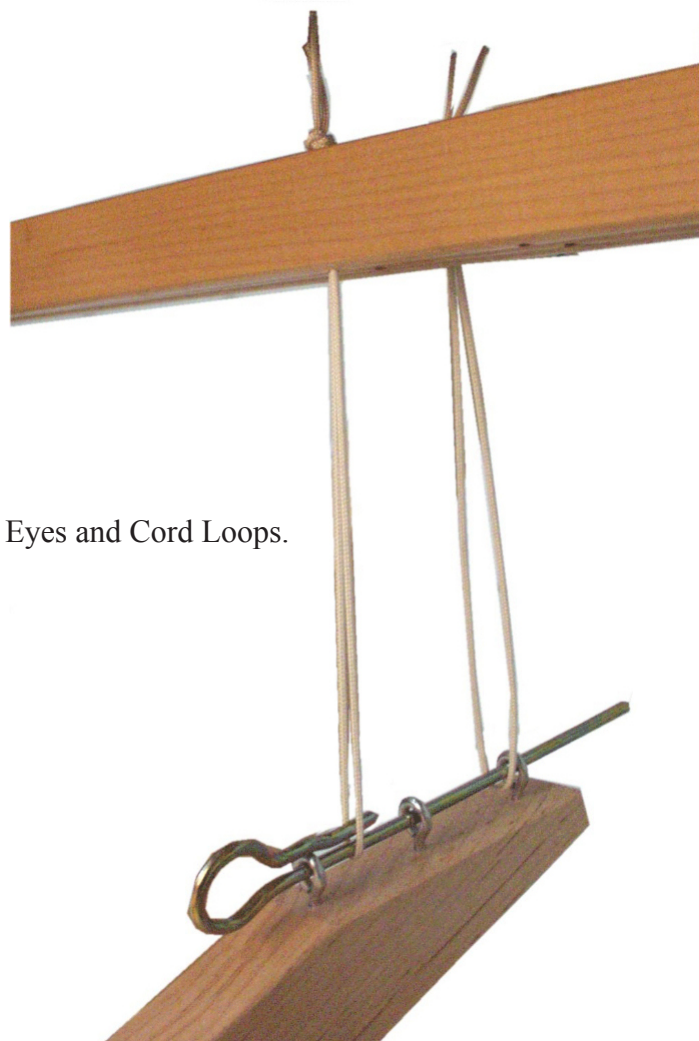
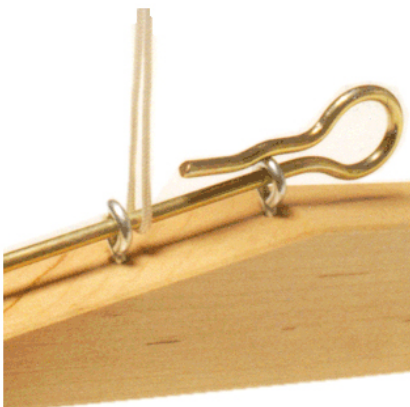

BEAMING

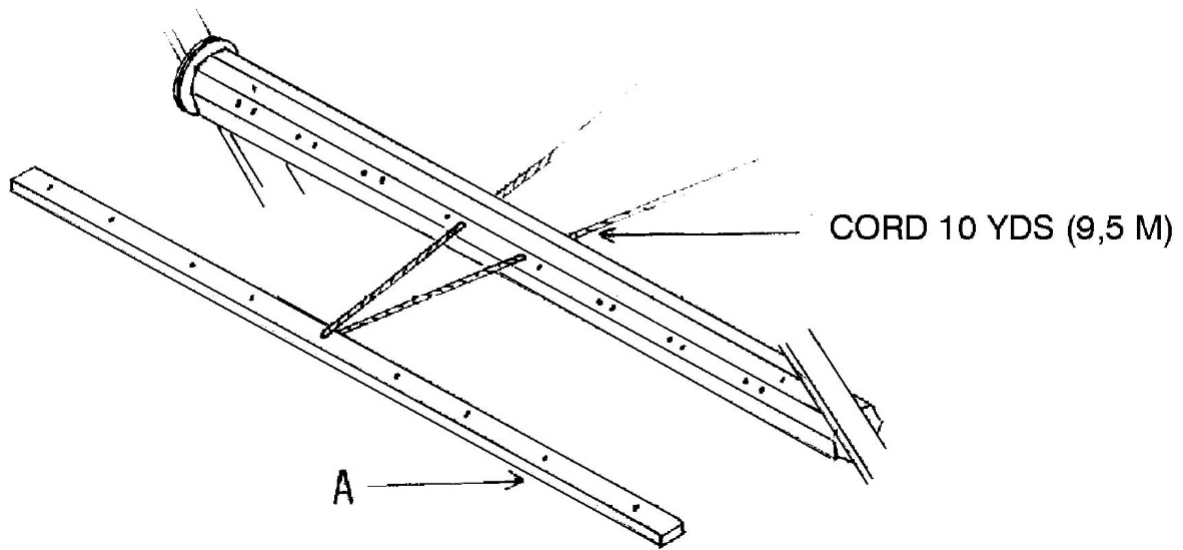

Thread the 10 yard (9 m) cord through the middle hole of beam stick A. Then pass the two ends (equal in length) of this cord through the middle holes of the warp beam.

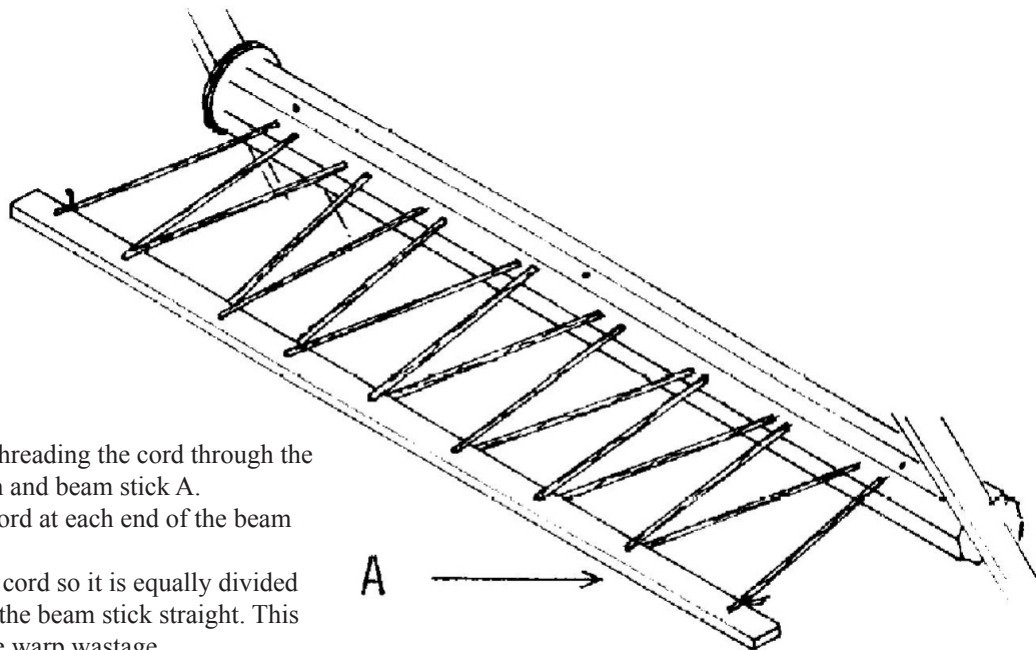

Continue threading the cord through the warp beam and beam stick A. Knot the cord at each end of the beam stick. Adjust the cord so it is equally divided and keeps the beam stick straight. This will reduce warp wastage.

Cord
 ½ of 5 yard (4.5 m)

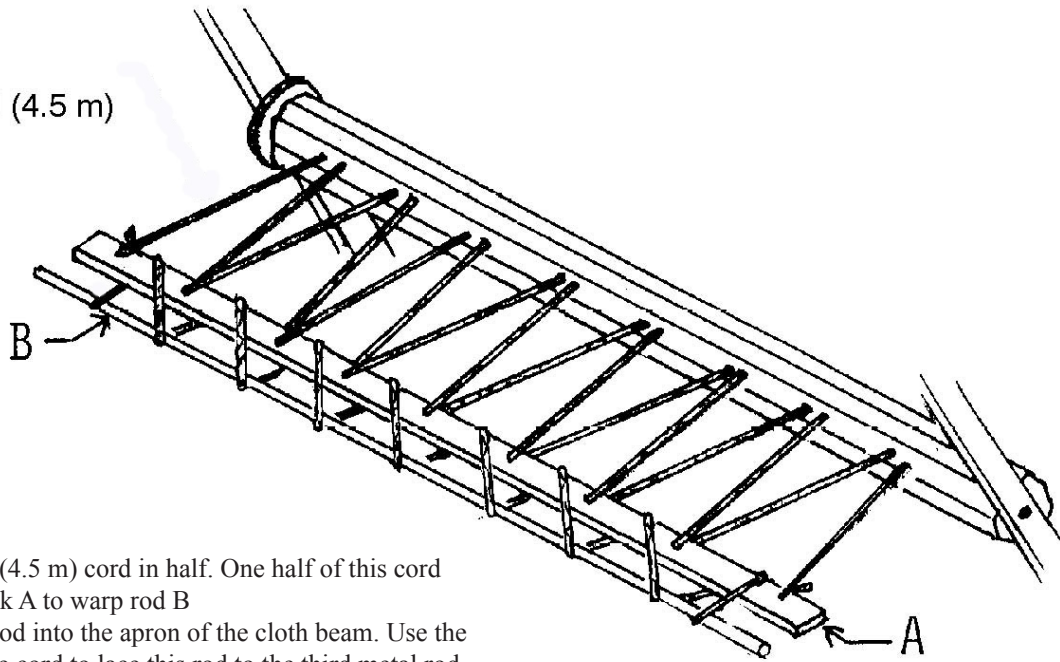

Cut the 5-yard (4.5 m) cord in half. One half of this cord laces beam stick A to warp rod B. Insert a metal rod into the apron of the cloth beam. Use the other half of the cord to lace this rod to the third metal rod.

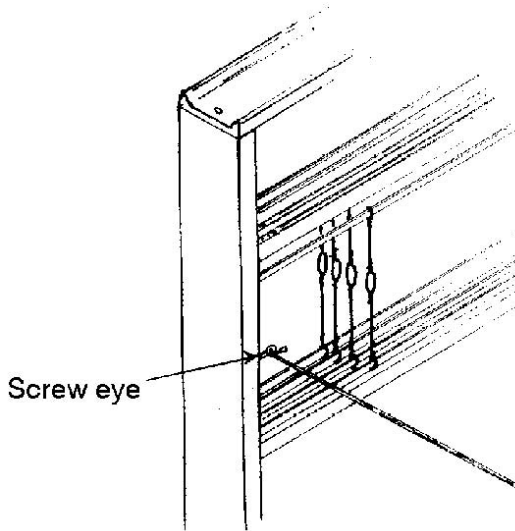

Screw eyes have been affixed to the inner side of the main post.
 After having passed a string through the holes of the lease sticks, tie the ends of this string to the thread beam and to the screw eye. Do the same operation with the other end of the lease sticks.

The lease sticks will then be held at a practical height for threading

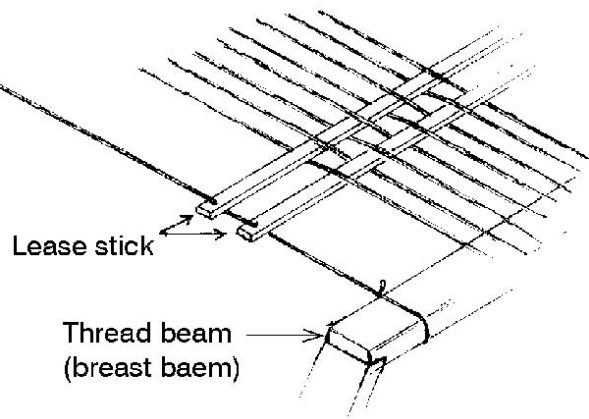

We at Leclerc encourage Weaver feedback on this and all our products. Please send your comments to Leclerc Loom Co. info@leclerclooms.com

HAPPY WEAVING