

**COMPACT 24”  
KIT 8 shaft  
1023-0000**



1573 Savoie  
C. P. 4  
Plessisville, Qc.  
G6L 2Y6

TEL: 819-362-7207  
FAX: 819-362-2045

[www.leclerclooms.com](http://www.leclerclooms.com)  
[info@leclerclooms.com](mailto:info@leclerclooms.com)

On receiving the kit, unpack and lay out the loom components.

Do NOT discard any packing material until all parts are inventoried.

Check the parts received against the parts list on pages #2 of the assembly instructions. Report any discrepancies to Leclerc immediately.



When we talk about right or left hand side parts, and front or back parts, it always refers to an upright loom seen from the front position.

The beater is not illustrated but it may remain on the loom during the conversion.

To assemble this loom, a minimum of 2 people are needed.

Loom Prepared by: _____
Inspected by: _____
Date: _____

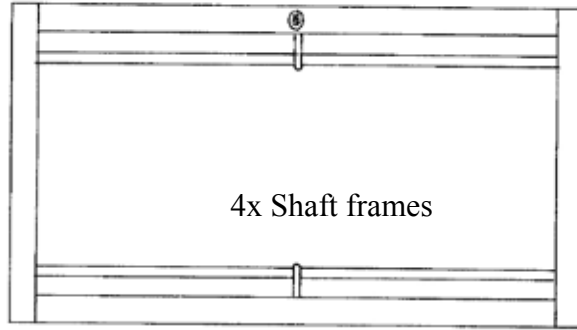
PARTS AS SHIPPED

Instruction video.  
In case of difference between the video and the instruction, follow the written instruction.



1x Treadle set crossmember (29" & 5 holes)

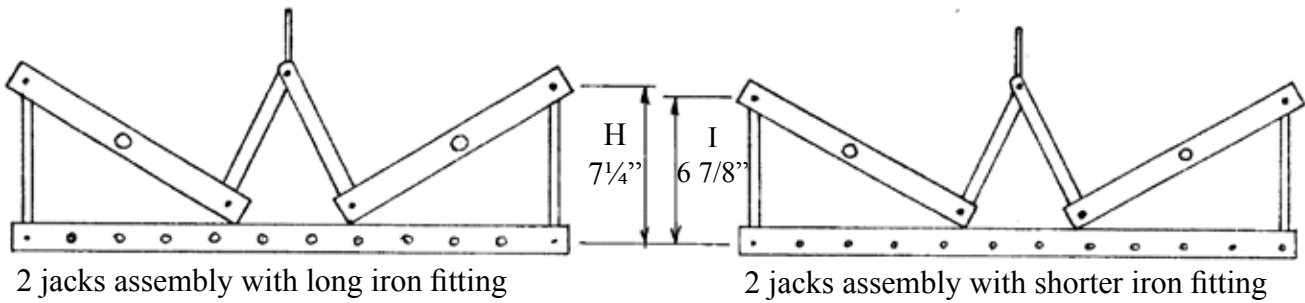

Note for Leclerc in French :  
Enfiler les rondelles 3/16" dans chaque cordes et attacher par paquet de 12 cordes.

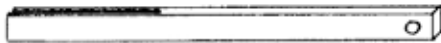

4 treadles



36 treadle cords 9" with washers 1/8" x 3/16"



4 exagonal nuts 10-24



36 washers 3/8" (10mm) NYLON



2 washers 5/16" (8mm)



4 push nuts 5/16" (8MM)

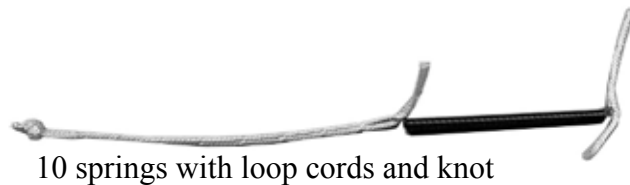

10 springs with loop cords and knot



Round head screw 10 X - #12 x 3/4" (20mm)



2 treadle set bloc with 2x screws no 14, 2"



1 Red and 1 Black screwdriver

Unhook and remove the  
brake cord from the brake system and  
from the brake treadle

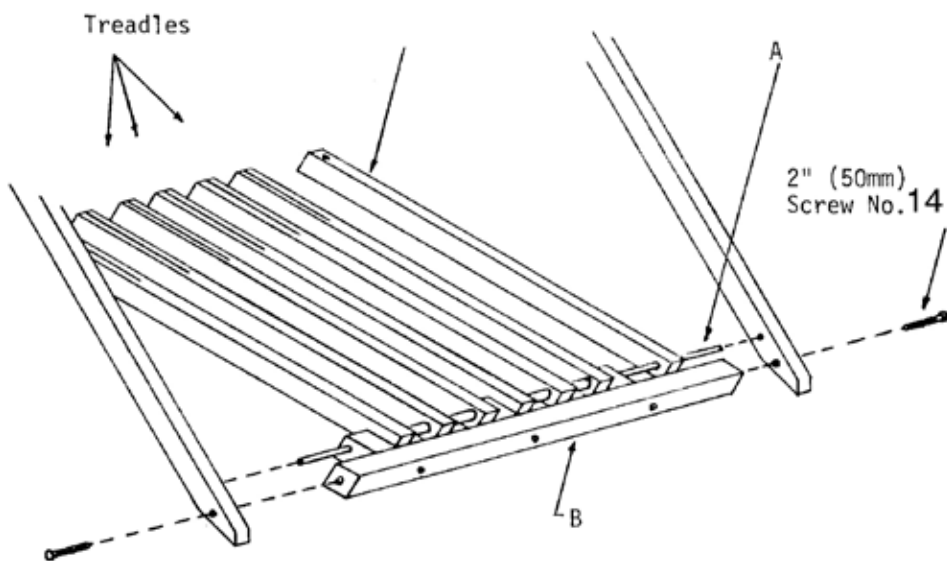
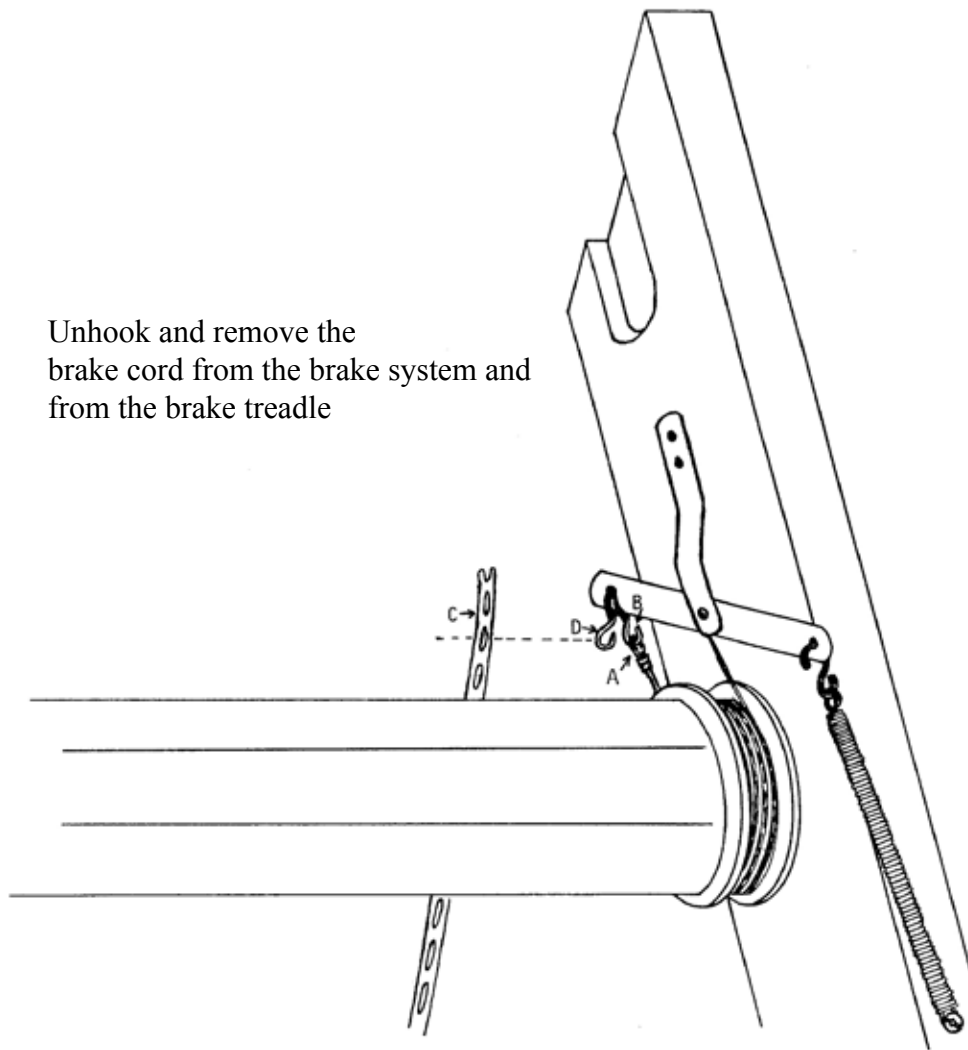

Remove the two (2) (50mm)  
round-headed screws No.  
14 that hold the treadle  
cross-member B, and spread  
the two (2) front legs out  
in order to disengage the  
treadle rod C. Remove the  
treadle set.

**Remove all shaft frame from the loom and all treadle cords from the jacks**

Fold the loom and lay it down on its front breast beam.

Remove the four 1½" (40mm) round-headed screws No. 8 that hold the rear jack box board E and remove the board.

Take off the two (2) round pieces of wood (short) F' and the two (2) round pieces of wood (long) G. Save the long round pieces of wood for the treadle set.

Remove jacks 1 to 4 still on the loom noting that the jacks no 1 and 2 are not the same as the jack no 3 and 4. Put them on the side jacks 1 and 2 together and jacks no 3 and 4 together.

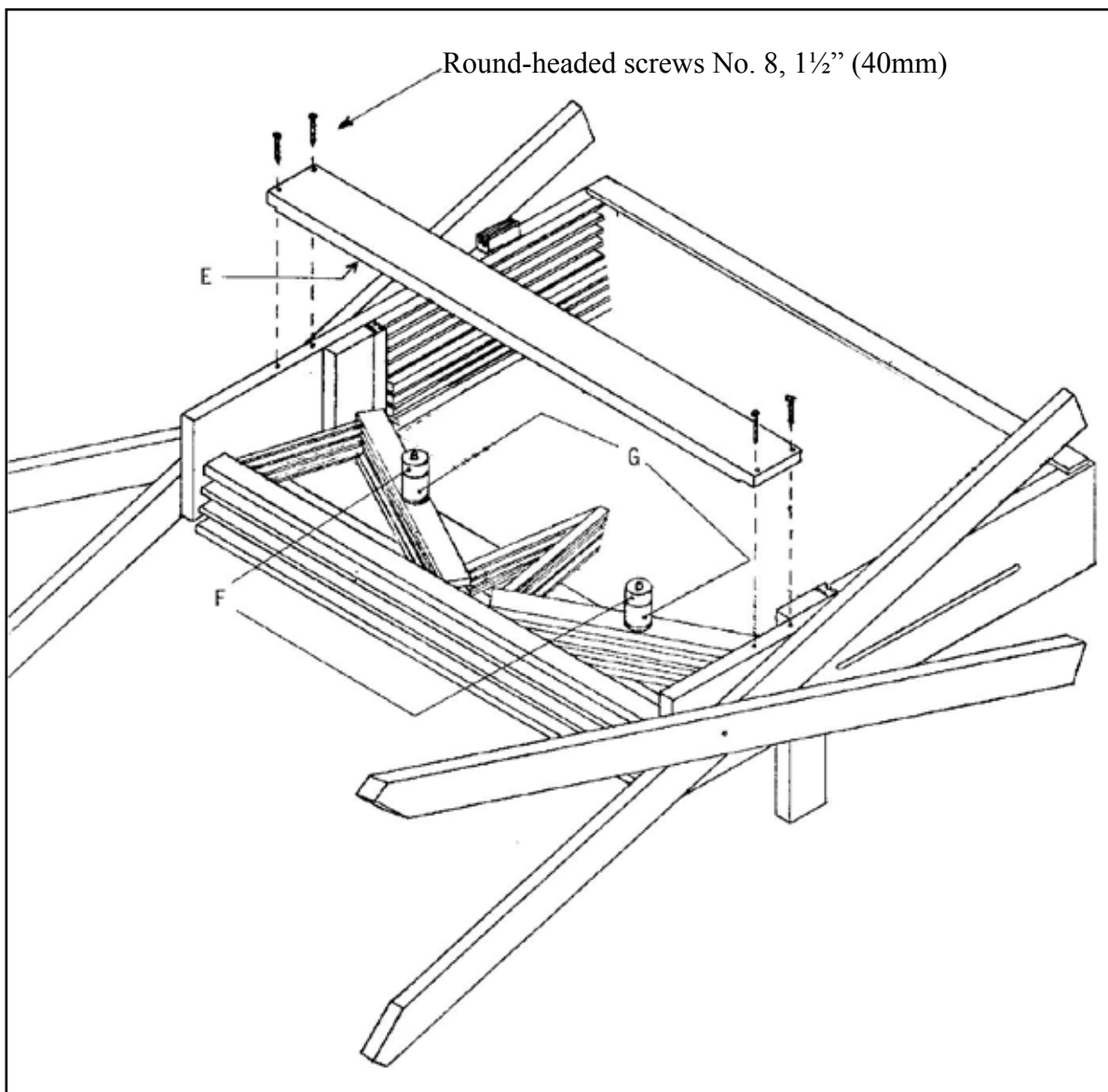

JACKS #1 AND #2 (FRONT)

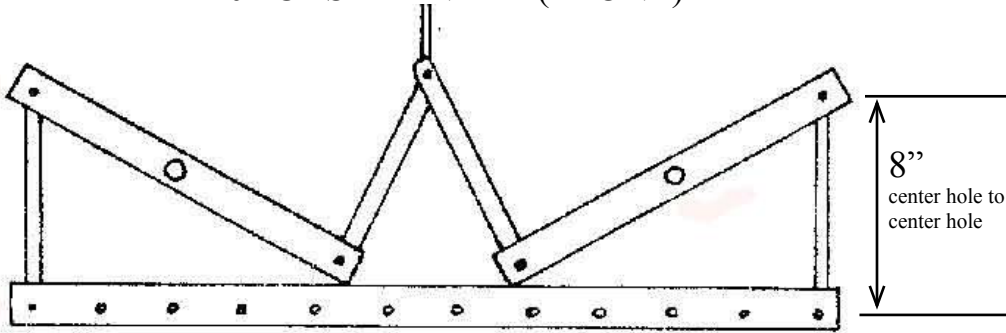

Make sure to identify and place correctly the right jack to the right order.

JACKS #3 AND #4

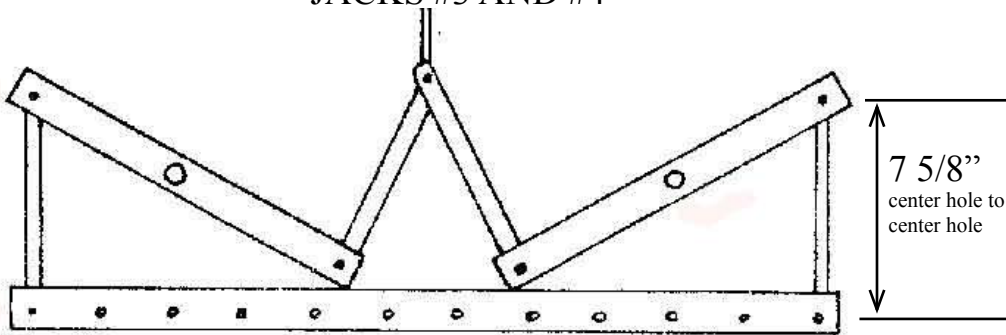

KIT JACKS #5 AND #6

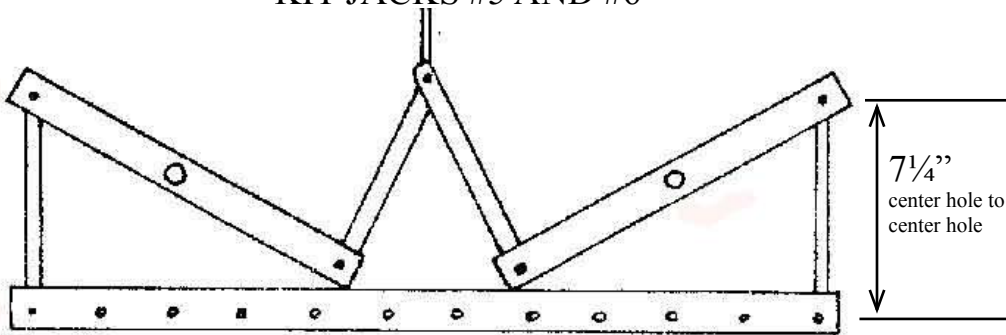

KIT JACKS #7 AND #8 (BACK)

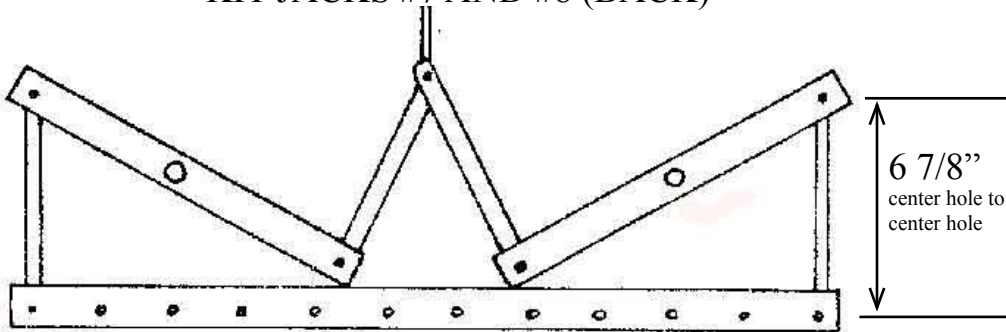

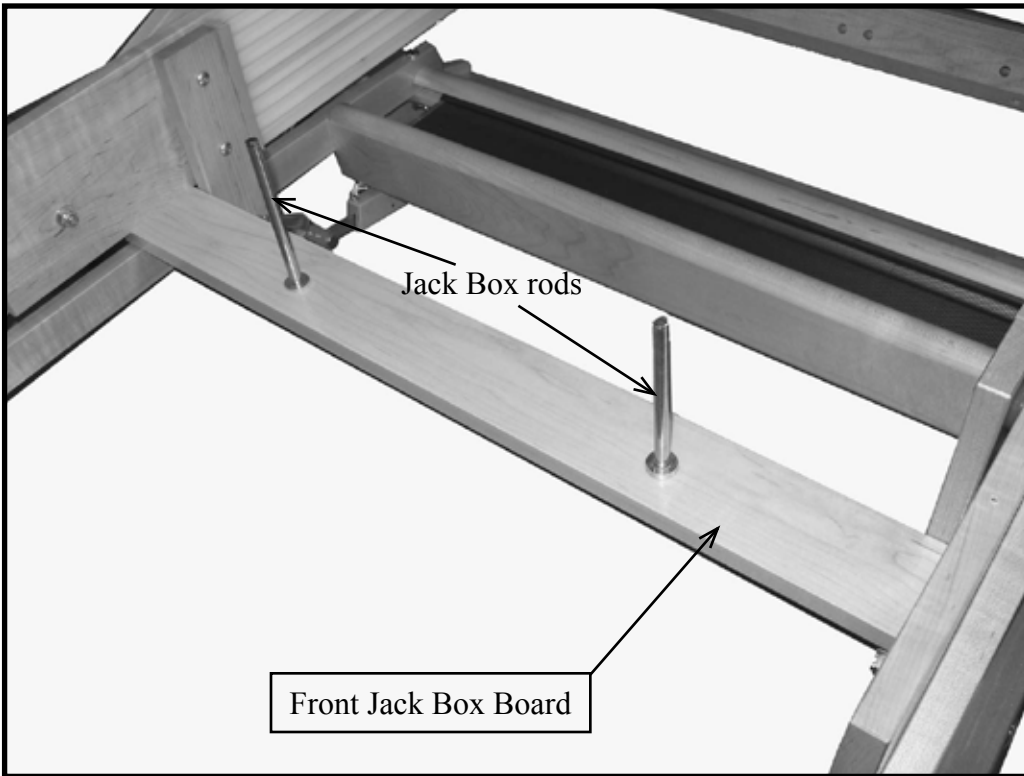

Place successively the 36 x 3/8" washers and the 8 sets of jacks following the drawing on next page.

IMPORTANT: SEE NEXT PAGE

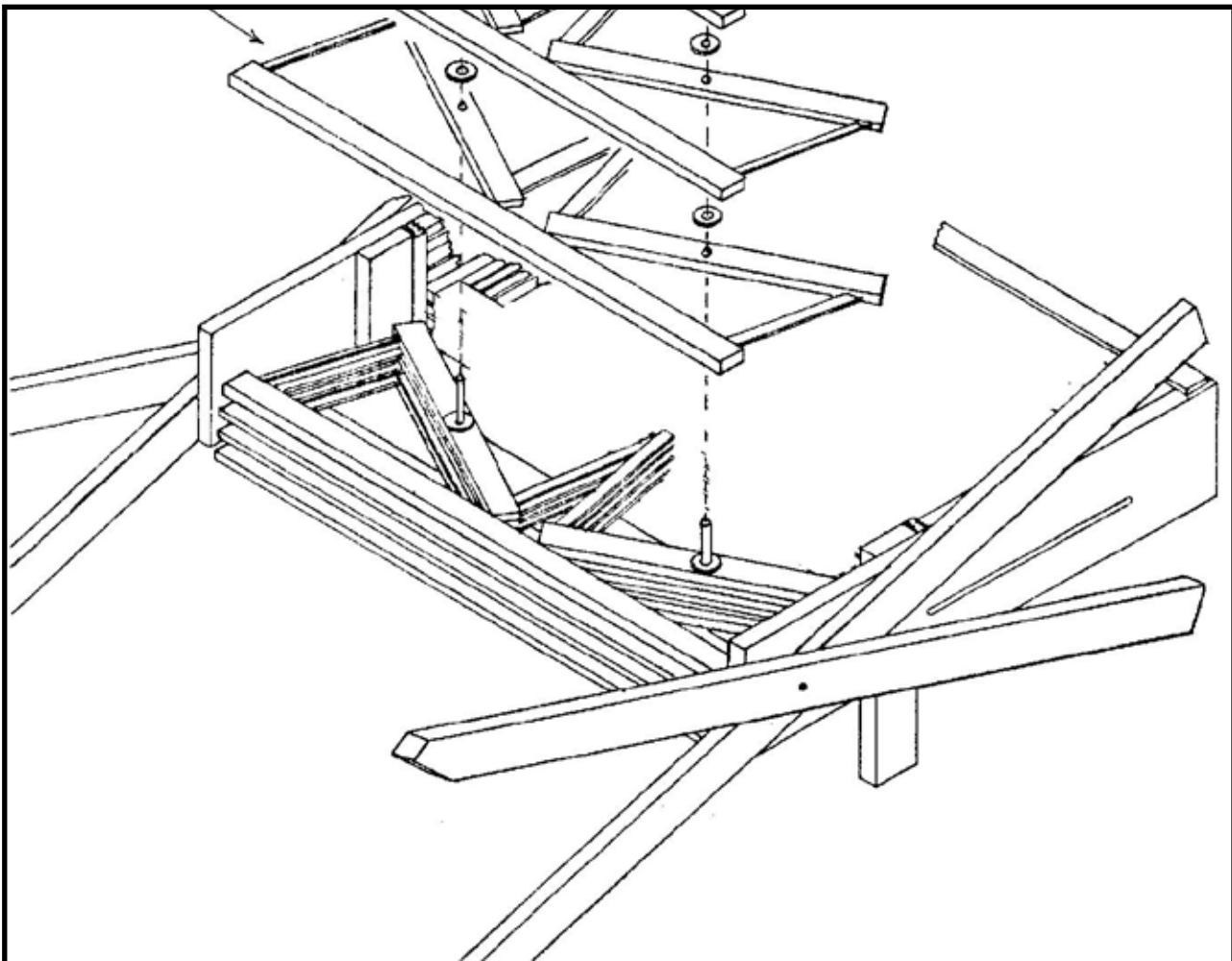

# JACKS IN THE JACK BOX

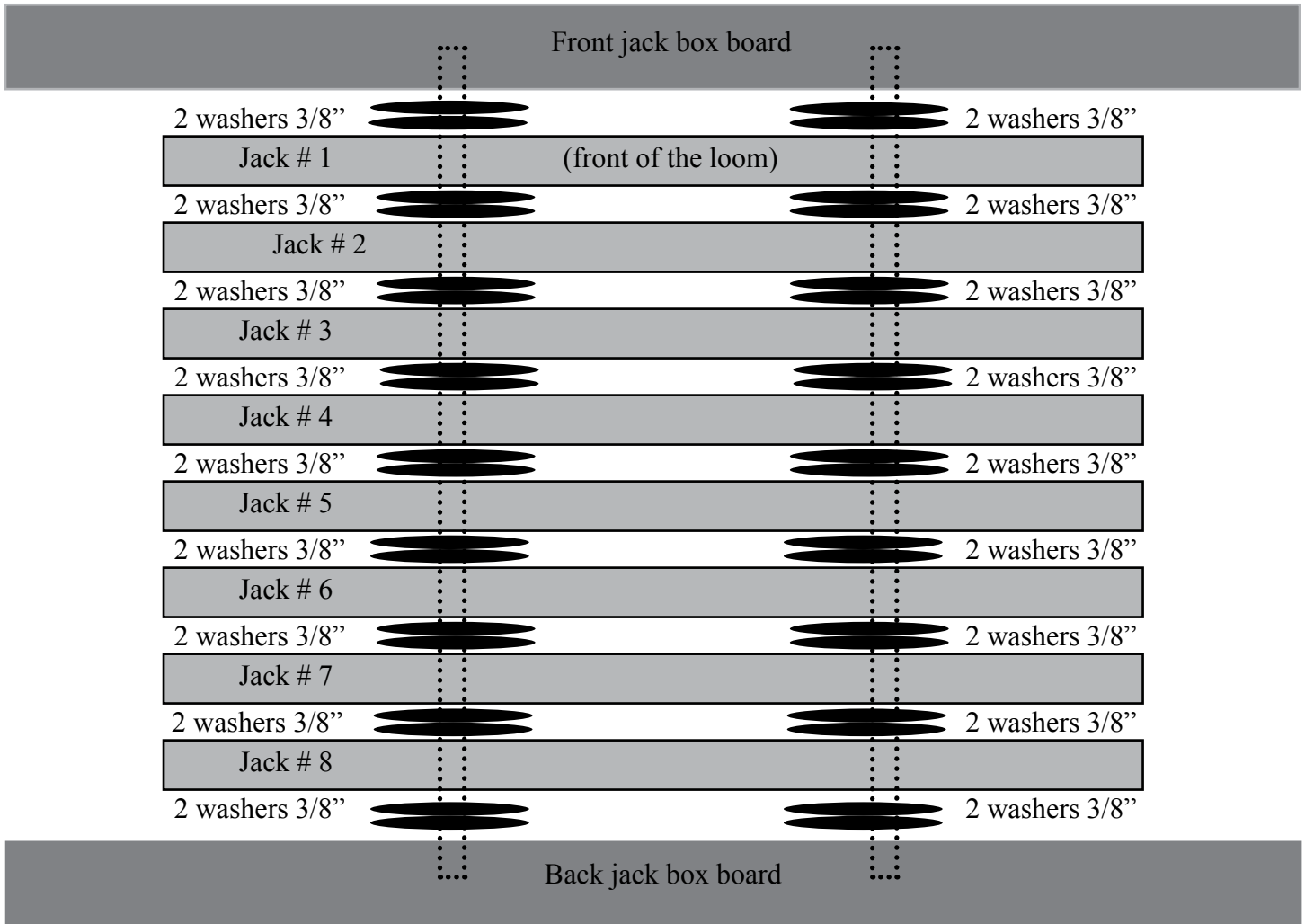

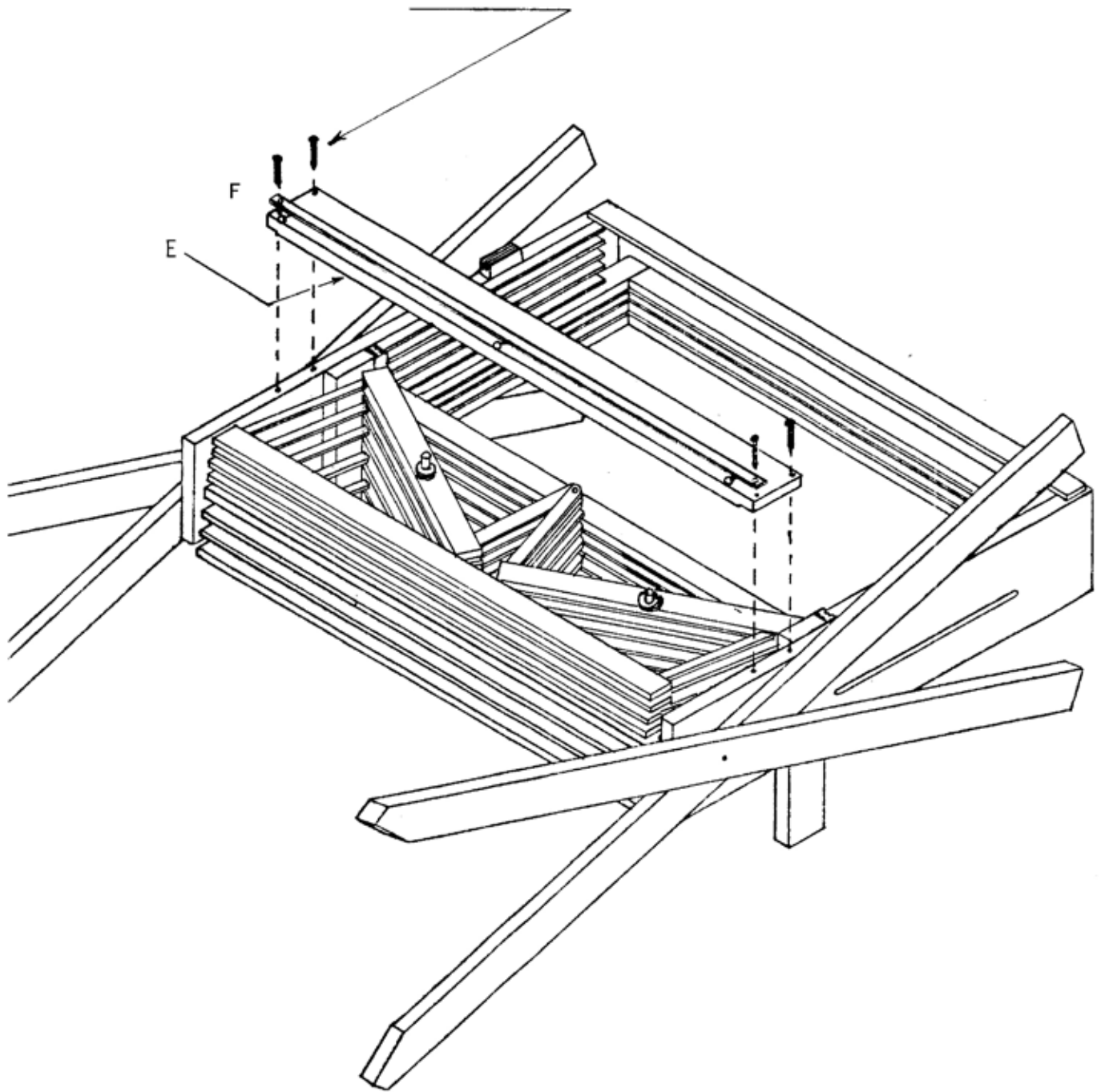



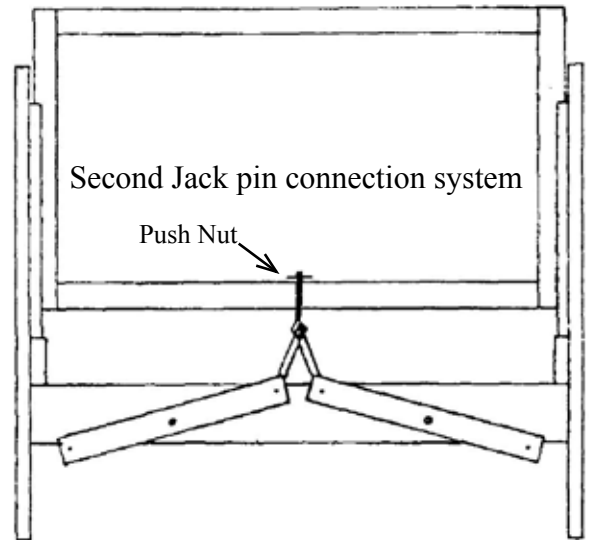
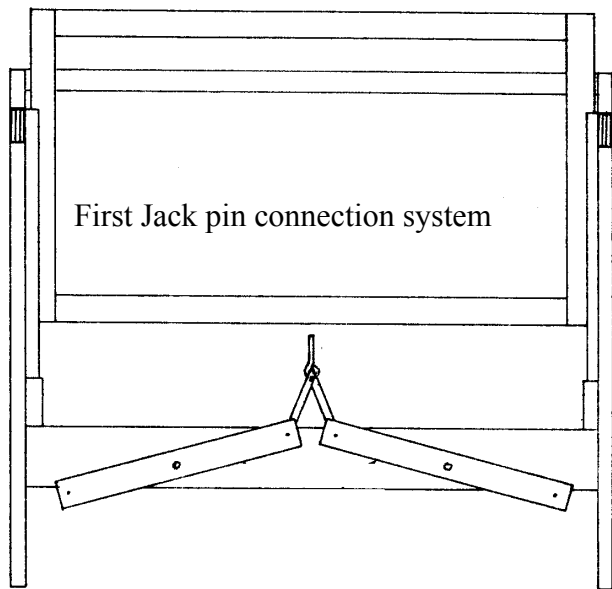

Over the years, there have been 3 different type of connection between the jack pin and the shaft frame. Make the connection according to the system you have for shaft #1 to 4 and following the Present system for shaft #5 to 8.

For the Present system, we strongly recommend that you have those nuts installed at all times.

**TO INSTALL HEDDLES:**

Disconnect the center of both heddle supports of a shaft frame and take it out of the end frame by bending it. For more information, see the book supplied with the loom “Warp & Weave”.

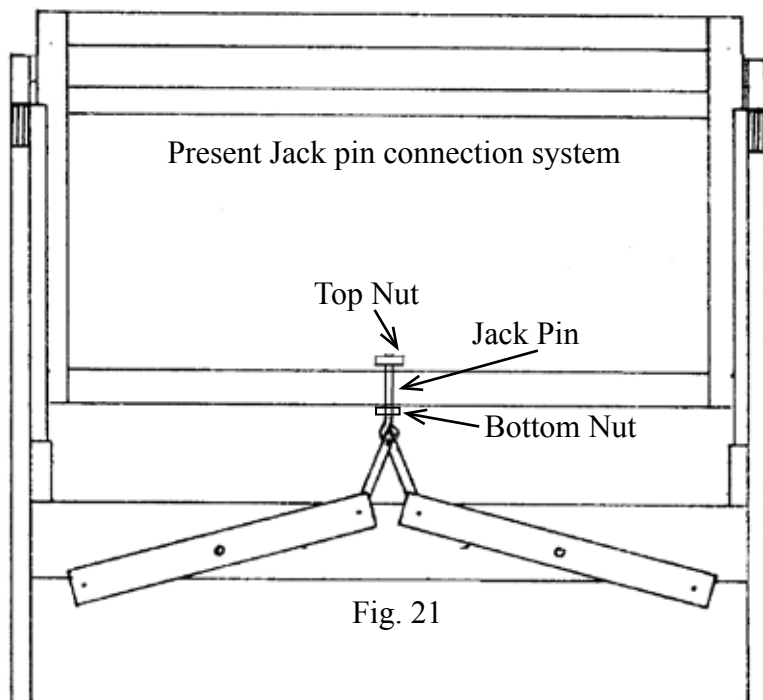
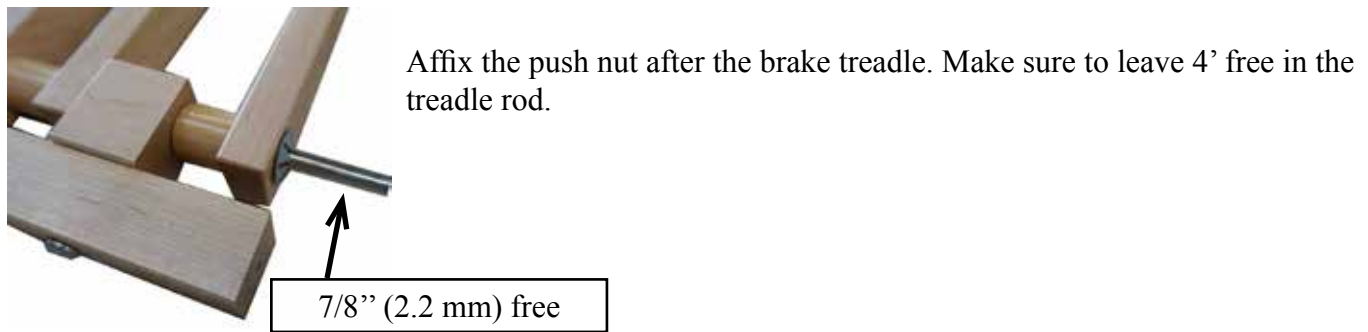
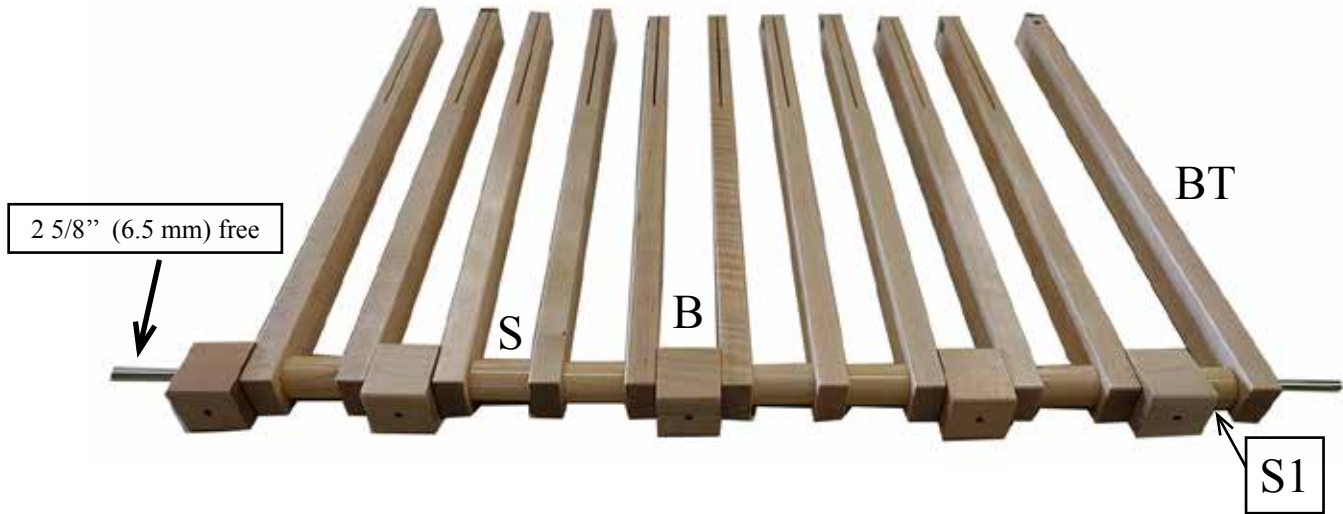

Fig. 21



Assemble the treadle set using the 10 treadles, 5 treadle blocs (B), 6 treadle spacer 1.5'' (S) one spacer 1'' (S1), one brake treadle (BT) and one push nut. Start making the assembly at the left side. Leave 2 5/8'' of rod free at the left side.



Affix the push nut after the brake treadle. Make sure to leave 4' free in the treadle rod.



Install the treadle set to the loom. Insert the left side rod to the post. Insert the right hand side and affix the treadle cross member with 2 screws no 14, 2'' (50 mm)

# Brake treadle

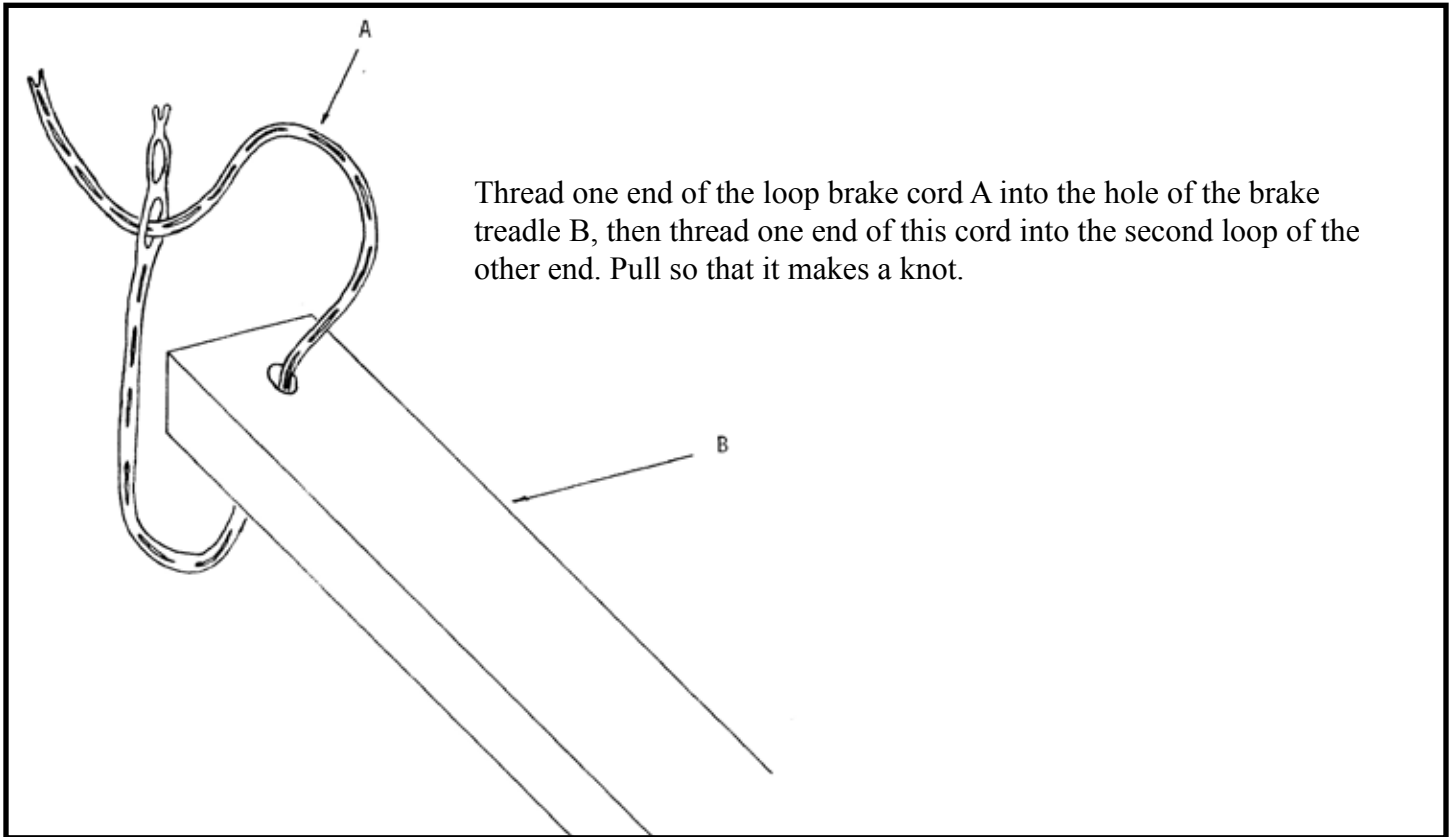

**+ COMPACT 24”  
NEW IMPROVE BRAKE KIT (1023-0002)**

Install treadle cords with the washers under the treadles as shown here

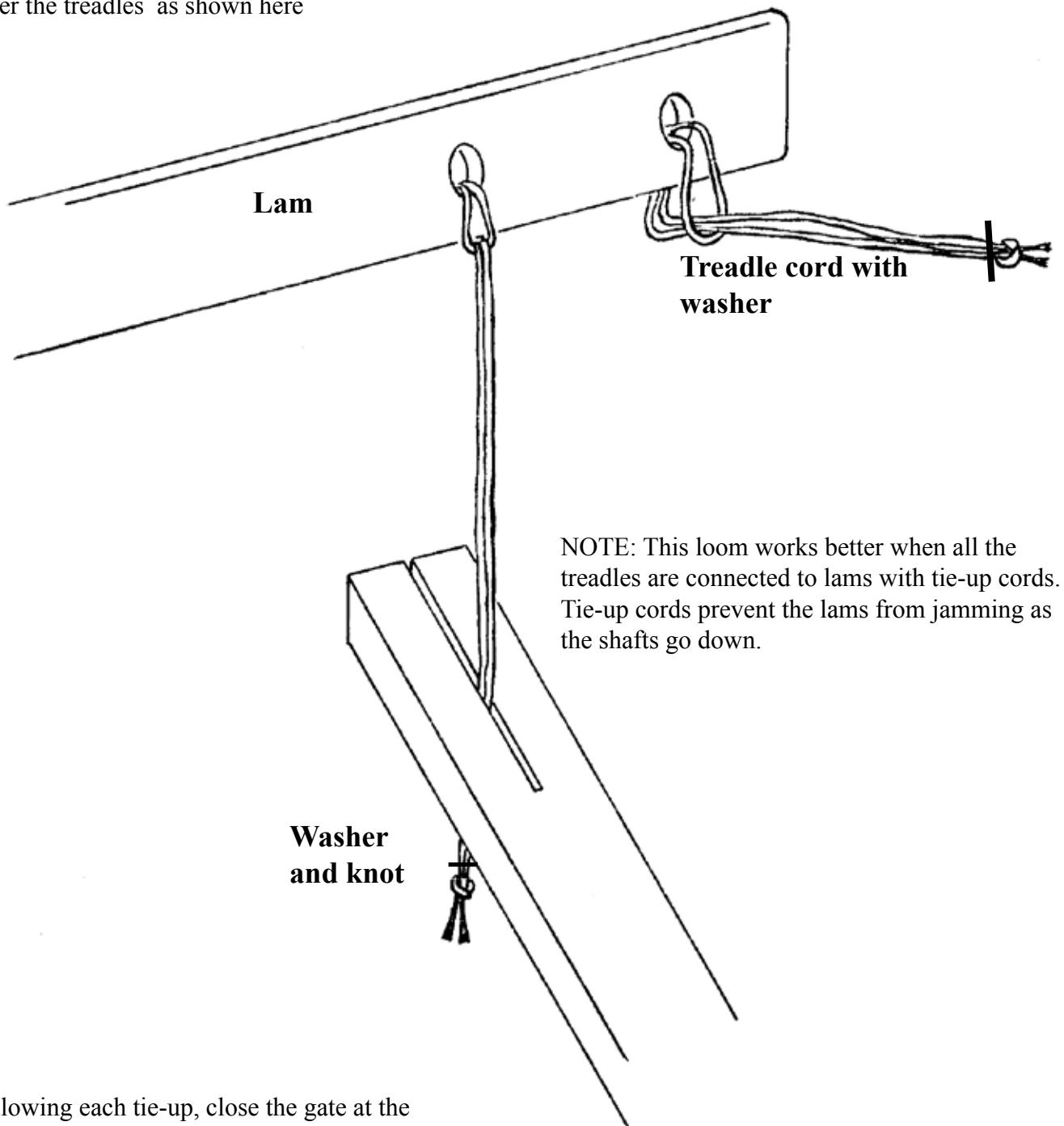

Following each tie-up, close the gate at the end of each treadle.

Note that if the gate on a treadle is hard to open/close, it may be necessary to slide the Texsolv Treadle Spring Cord a few inches along the treadle closer to the front of the loom to make opening/closing the gate easier.

Once the gate is closed the Treadle Spring Cord can be re-positioned back closer to the gate."

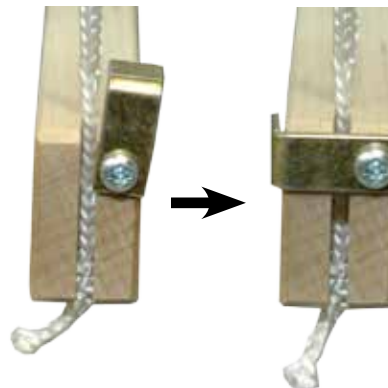

## SPRING KIT

When more than 6 treadles are connected to the lams, the weight of the treadles can lift the shaft frames up or make the movement down very difficult.

To correct this you will have to install springs that will support the weight of each treadle.

Use the screws of the back jack board to install the springs

Make a loop cord knot so the length of the spring with the loop cord will hold the weight of the treadle.

Slide the loop cord end (knot) under each treadle.

It is preferable to always have a small amount of tension on the treadle spring when the treadle is in the up position.

Install in the back of the jack box the screws (#12, 3/4") to anchor the loop cord. Make sure that each screw align with the treadle.

Used the drill 11/64" to make the pre-drill holes.

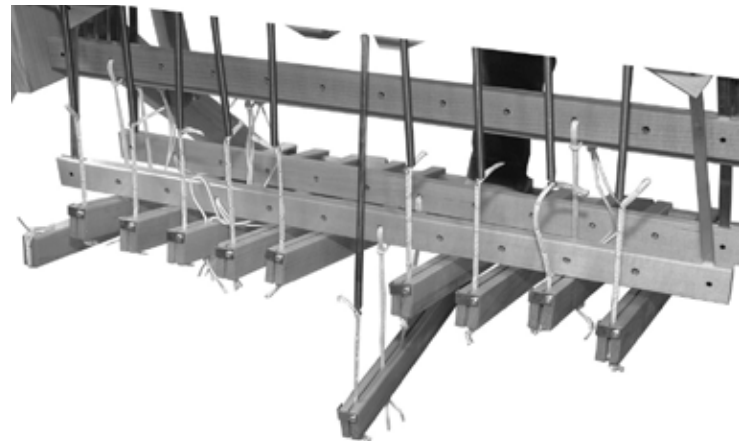
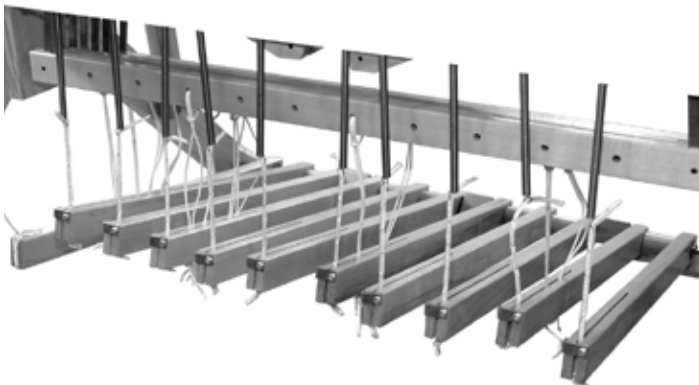
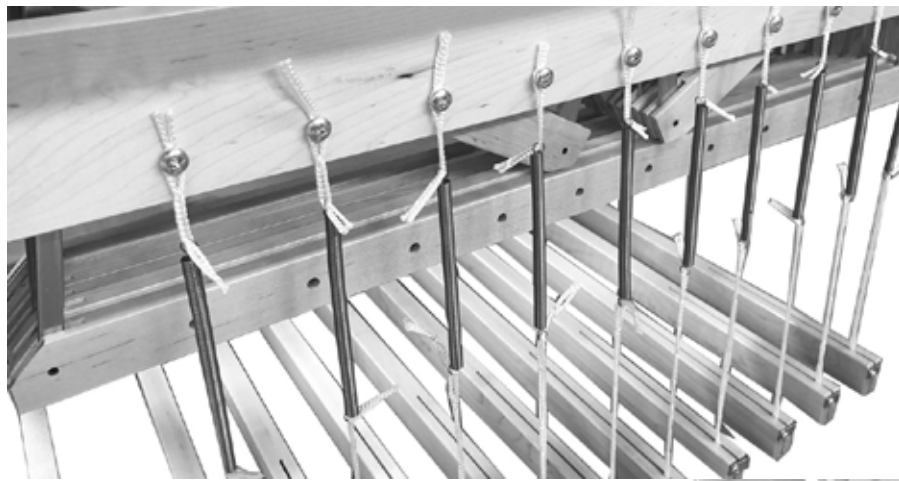



To fold the loom, release the tension by pressing the brake treadle, then loosen the plastic handles on each side of the loom and pull these upward. Tighten the handles.  
The loom can fold even with fabric on it.

**IMPORTANT NOTE: Be careful when closing and opening the loom.  
To avoid damage and injuries, NEVER completely remove the plastic handle.**

**MAINTENANCE:**

In order to get the maximum efficiency from your loom, we recommend you periodically spray a lubricant (silicone) on the plastic slides on each side of the loom.

We at Leclerc encourage Weaver feedback on this and all our products. Please send your comments to Leclerc Loom Inc.

HAPPY WEAVING