

**COMPACT 24”
8 SHAFTS
1022-0001**



1573 Savoie
C. P. 4
Plessisville, Qc. Canada
G6L 2Y6

TEL: 819-362-7207
FAX: 819-362-2045

www.leclerclooms.com
nfo@leclerclooms.com

On receiving the loom, unpack and lay out the loom components. Do NOT discard any packing material until all parts are inventoried.

Check the parts received against the parts list on pages #2 to #6 of the assembly instructions. Report any discrepancies to Leclerc immediately.



To assemble this loom, a minimum of 2 people are needed but it is recommended you use 3.

Loom Prepared by: _____

Inspected by: _____

Date: _____

PARTS AS SHIPPED

Note for Leclerc in French :
 Rondelles entre chaque marmousset:
 Débuter et finir par 3 d'un côté et un de l'autre pour
 égaliser le marmousset.
 Puis alterner 1 de chaque côté et 2 de chaque côté.

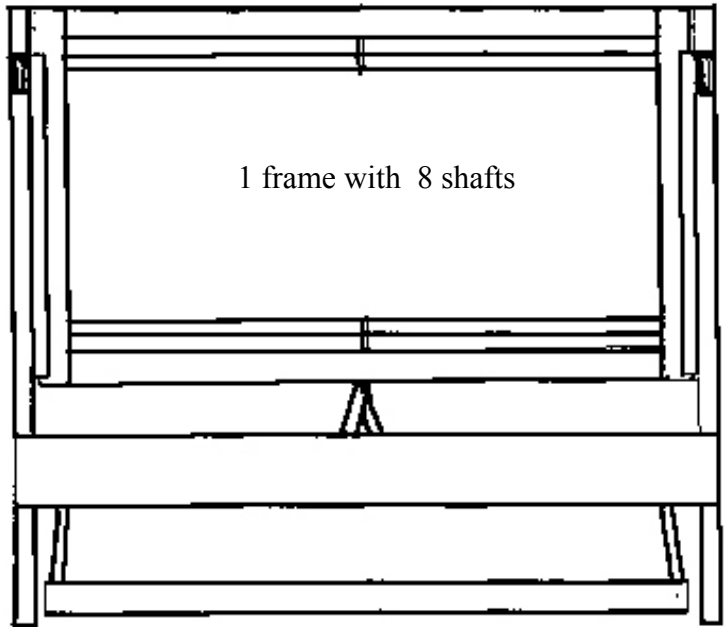
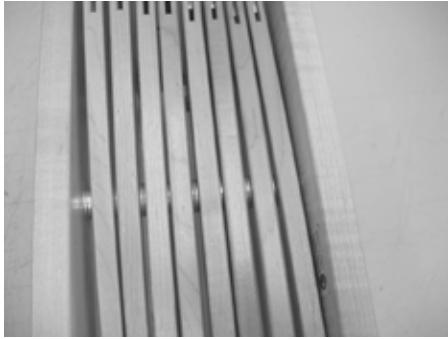

10½"



600 heddles 10½"



1 threading hook



1 red screwdriver & 1 black

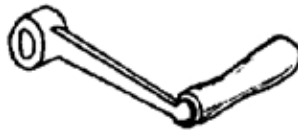

1 crank (Octagonal)

Note for Leclerc in French :
 Enfiler les rondelles 3/16"
 dans chaque cordes et attacher
 par paquet de 12 cordes.



3x12 treadle cords 9" with
 washers 1/8" x 3/16"



1 - 5 yard cord
 2 - 10 yard cords



1 boat shuttle (6122-1000)



1 aluminum wrench



1 adjustable wrench

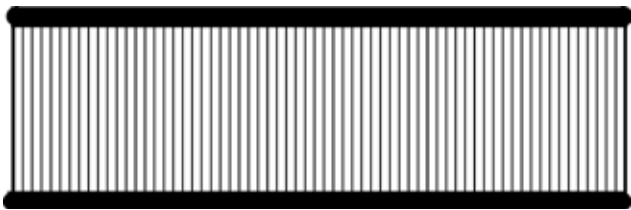

1 reed

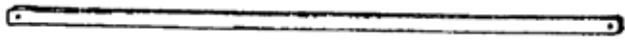

2 lease sticks 25" (metal)

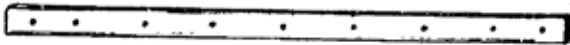

2 beam sticks 24½" (metal)



2 warp rods (metal)

1 right hand side front post
(with brake cable) 44"

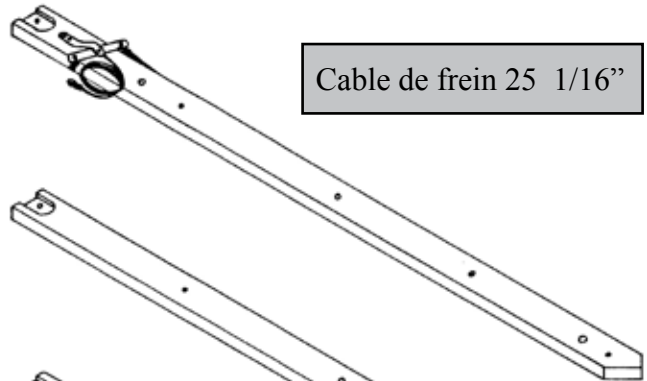

1 left hand side rear post 44"

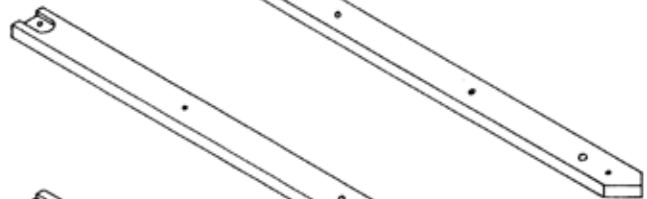

1 left hand side front post 44"

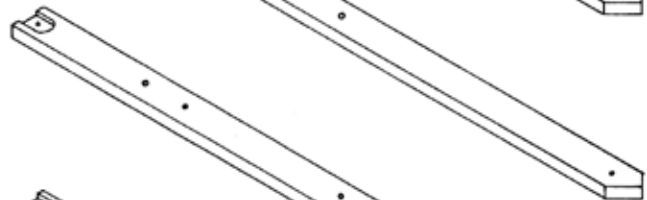

1 right hand side rear post 44"

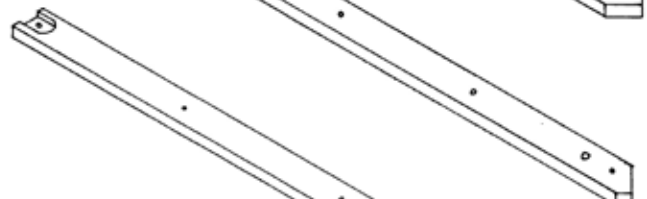

1 lower rear cross-member 30½"



1 treadle cross-member 29"

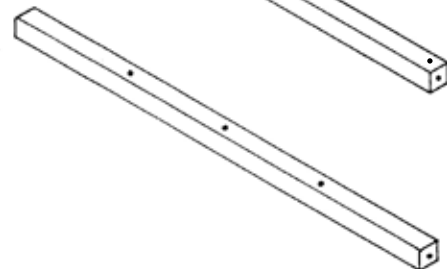

NEW WHEEL KIT

THE KIT INCLUDES:

- 2 wood blocks with wheels
- 2 carriage bolts 2³/₄" x 1/4"
- 2 Washers 1/4"
- 2 wing nuts 1/4"
- 2 screws #8 2"



1 cloth beam 25"



1 warp beam 28 9/16"



1 thread beam 29 1/2"

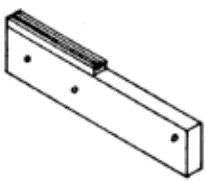

1 left hand side cloth beam support

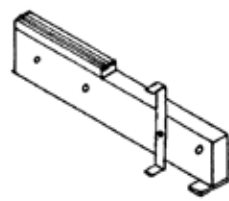

1 right hand side cloth beam support with ratchet pawl 10 1/2"

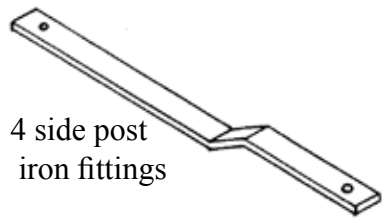

4 side post iron fittings



3 treadle blocks

2 Wood pegs 1/2" x 1 3/4"



1 take-up motion handle with 12" loop cord + 1 eyescrew

LECLERC NOTE:
Oeillet légèrement ouvert

Spring Kit

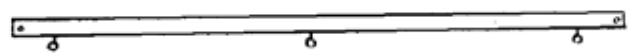

1 Wood board with 3 eye screws (28 3/4")



1 Metal rod with notch (27 1/2")



10 springs with loop cord and knot (9")

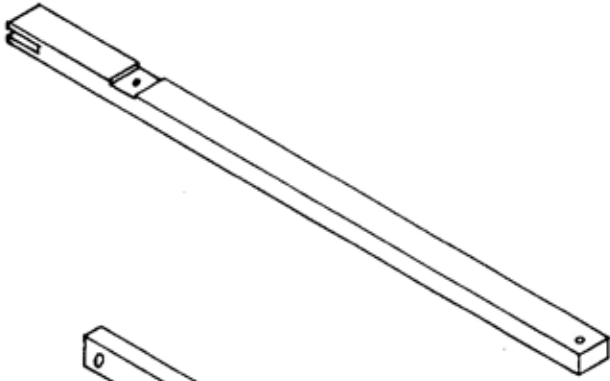

2 batten swords 27 $\frac{1}{4}$ "

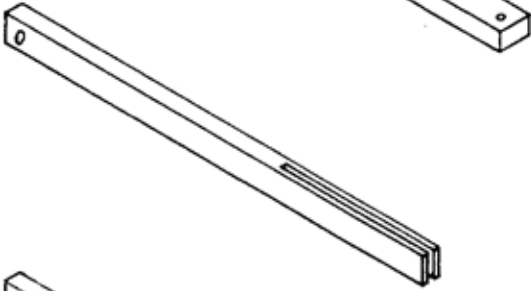

10 treadles 20"

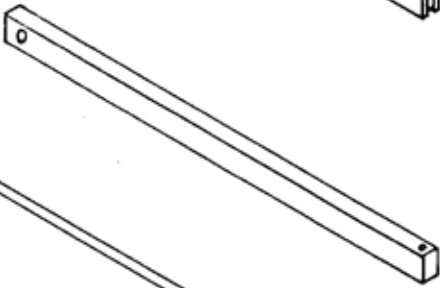

1 brake treadle 20"

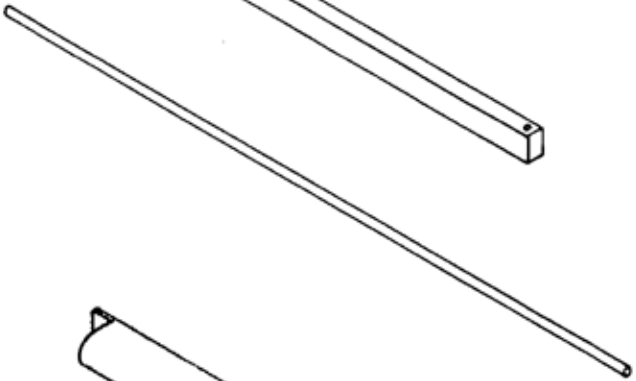

1 treadle rod 5/16" x 30"

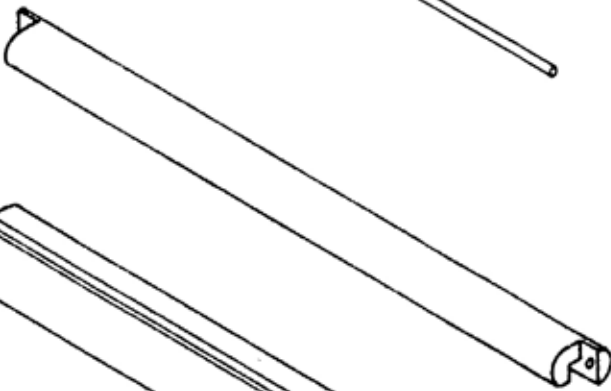

1 batten handtree 29"

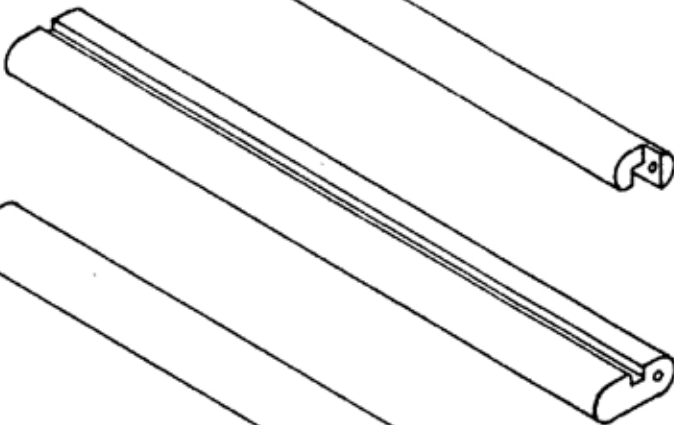

1 batten sley 27 $\frac{3}{4}$ "

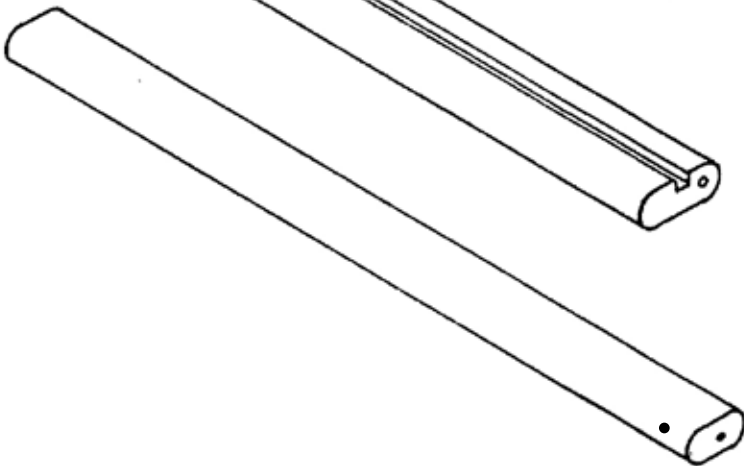

1 breast beam 31"

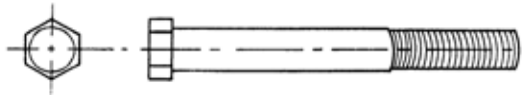

Machine bolts
1X - 5/16" x 3"

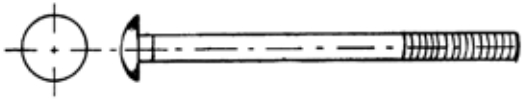

Carriage Bolts
2X - 1/4" x 2 1/2" (6mm x 65mm)
2X - 5/16 x 2 3/4" (8mm x 70mm)
2X - 5/16" x 2" (8mm x 50mm)



Washers
4X - 3/16"
8X - 5/16"
2X - 1/4"



HEXAGON NUTS
4X- Nylon auto lock 5/16"
(8mm)

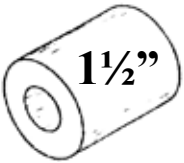

6 X Wooden spacer



Wing nuts
2 X - 1/4" (6 mm)



Nylon Wing nut for the Warp beam
advance control system



Round head screw
9X - #14 x 2" (50mm)
8X - #14 x 1 1/2" (40mm)
4X - #12 x 3/4" (20mm)



1 loop cords 24" for the brake treadle



4x push nuts 5/16"
for treadle set rod



1 DVD Instruction Video showing all
stages of installation.



2x plastic spacers



1 book Warp & Weave



2 black handles

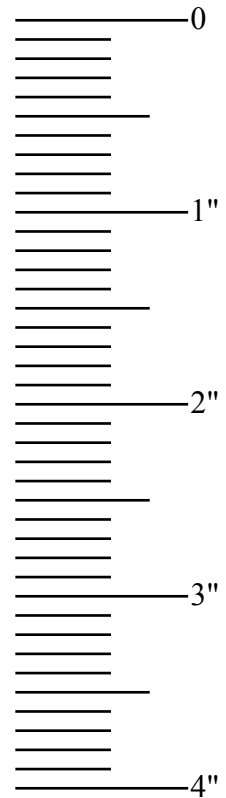

Lay down the frame (the bumpers must be on top) and pull on the lams C until the jacks D are parallel with the lams.

Insert the left support E into the left end of the cloth beam F, then insert the take-up motion handle G and the right support H, into the right side of the cloth beam. Push all these parts between the sides of the loom and fix each support with two 1½" (40mm) round-headed screws No. 14.

ATTENTION:
Application
of soap to the
screws will
make their
insertion
easier.

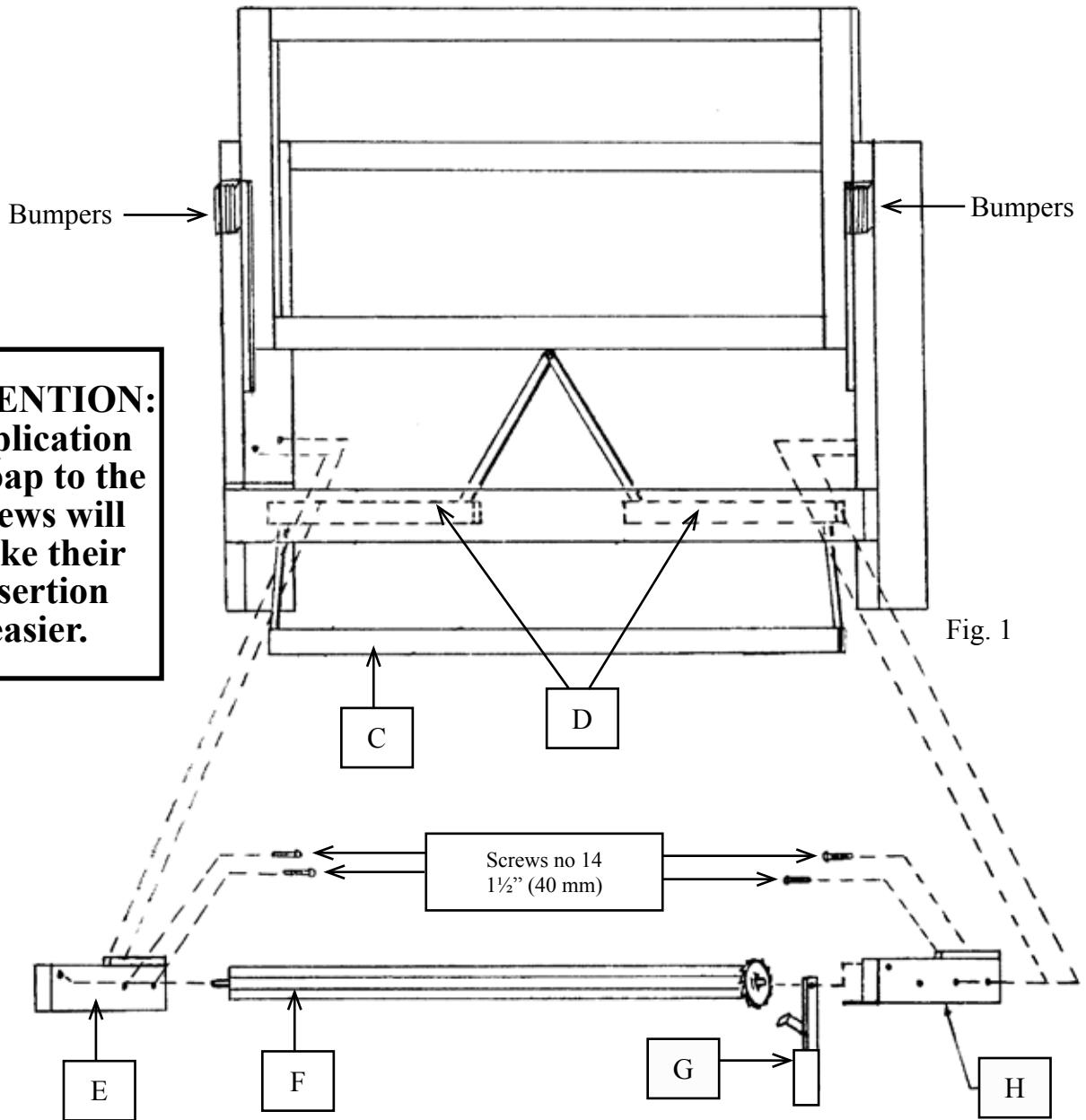

Heavy part on the back
of the loom

Make sure that the
ratchet pawl is in the
correct position.

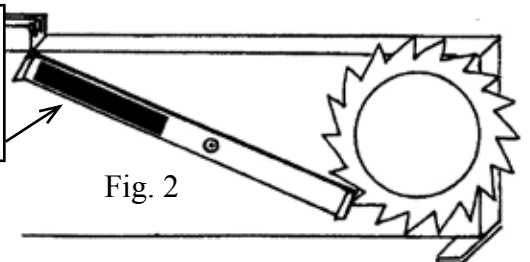

Fix an iron fitting A on each of the 4 legs . Make sure they are positioned exactly as shown in the diagram below.

Put a 3/16" (5mm) steel washer between the iron fitting and the leg. Screw them in using the 3/4" (20mm) round-headed screw No. 12. Do not over tighten so the iron can move freely.

The screw must be inserted into the smallest hole of the iron fitting.

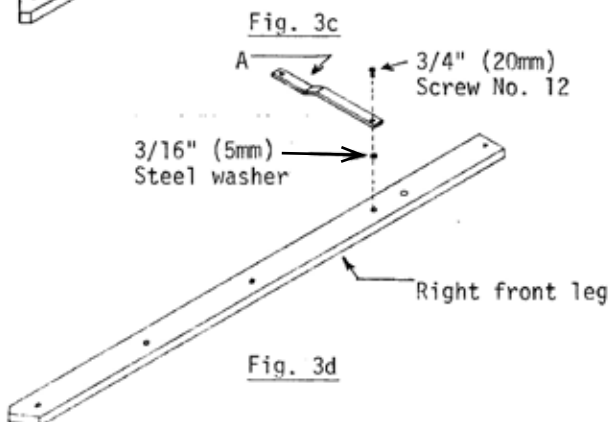
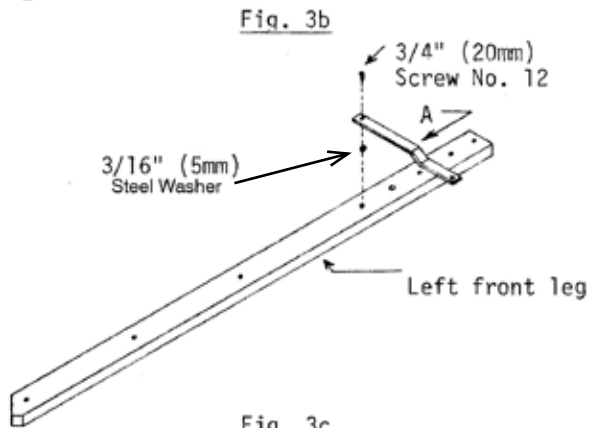
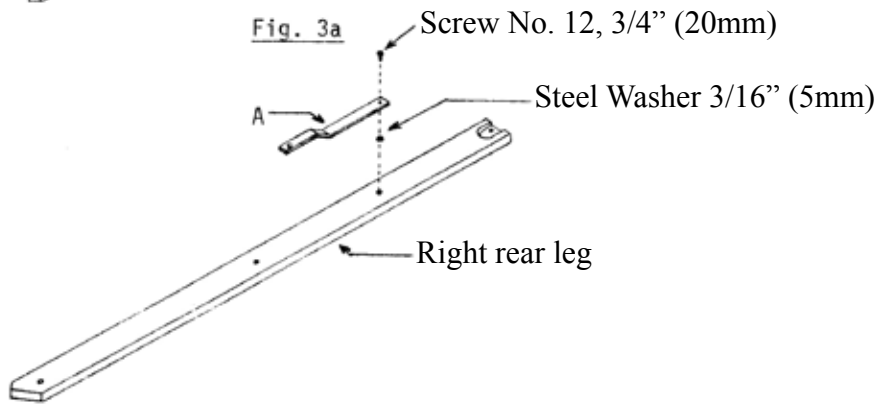
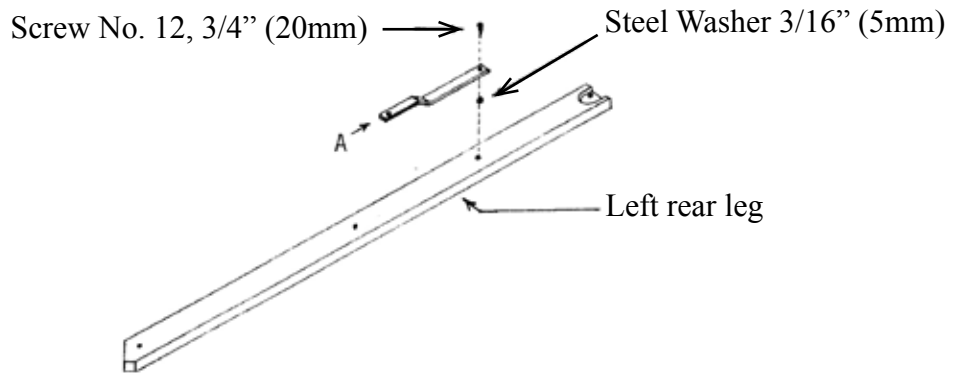

ATTENTION:
Application
of soap to the
screws will
make their
insertion
easier.

Place the loom frame on its right side. Fix the left front A and rear B legs to the left side of the frame with a 5/16" x 2 3/4" (8mm x 70mm) carriage bolt. With a hammer, hit on the head of the bolt until it is even with the leg B. Cross the legs so that the lower end of the leg B is towards the back and the lower end of the leg A is towards the front. Add a steel washer and screw a 5/16" (8mm) lock nut in without overtightening it. You must feel light resistance when you swivel the legs.

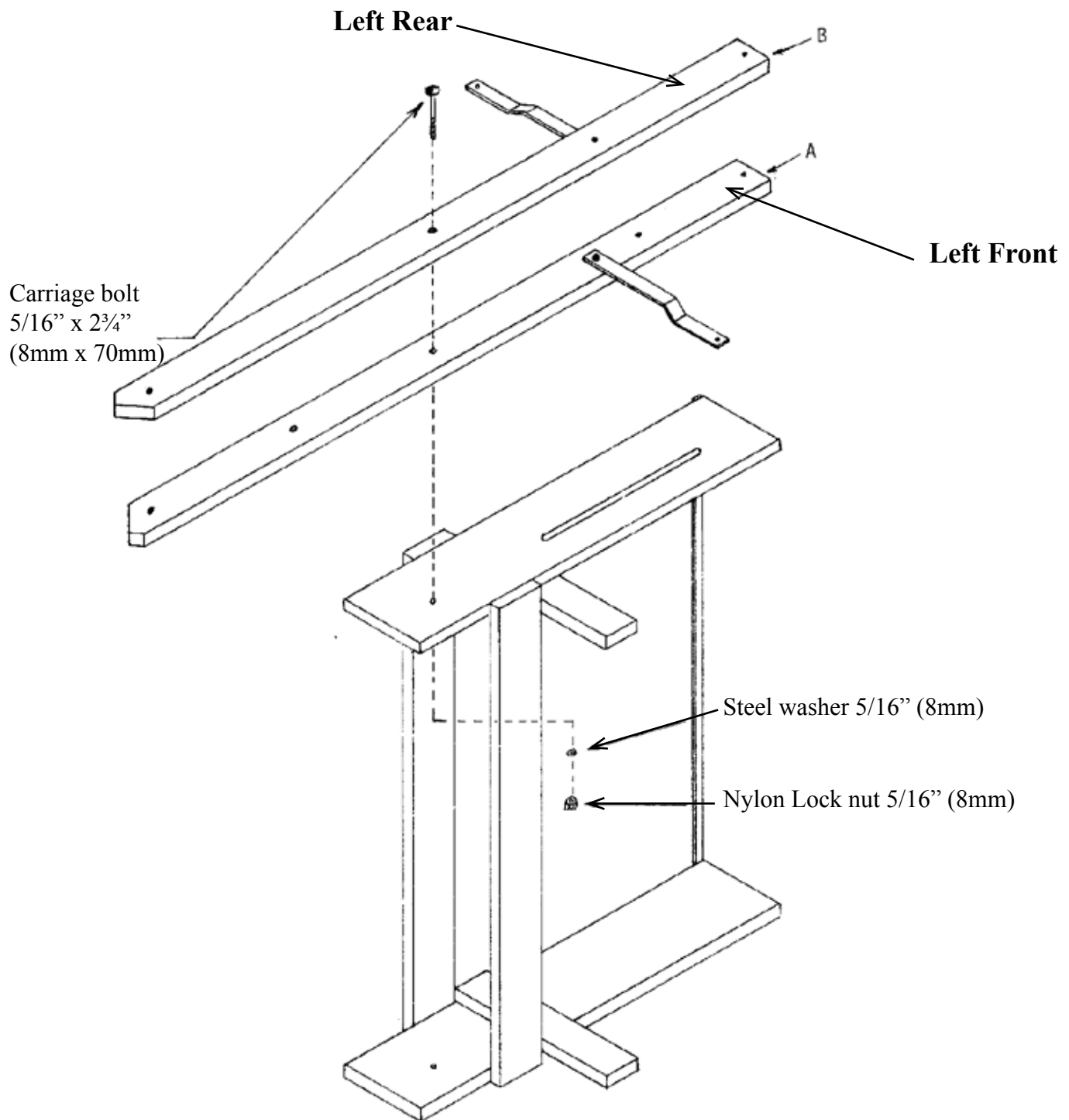

Fig. 4

Put a plastic spacer A in the groove as illustrated. Insert the threaded rod of the handle B. First into the front leg iron fitting C, then into the rear leg iron fitting D, then into the spacer A (fig 5). Screw the handle in the metallic plate E inside the groove and tighten it in the lower position.

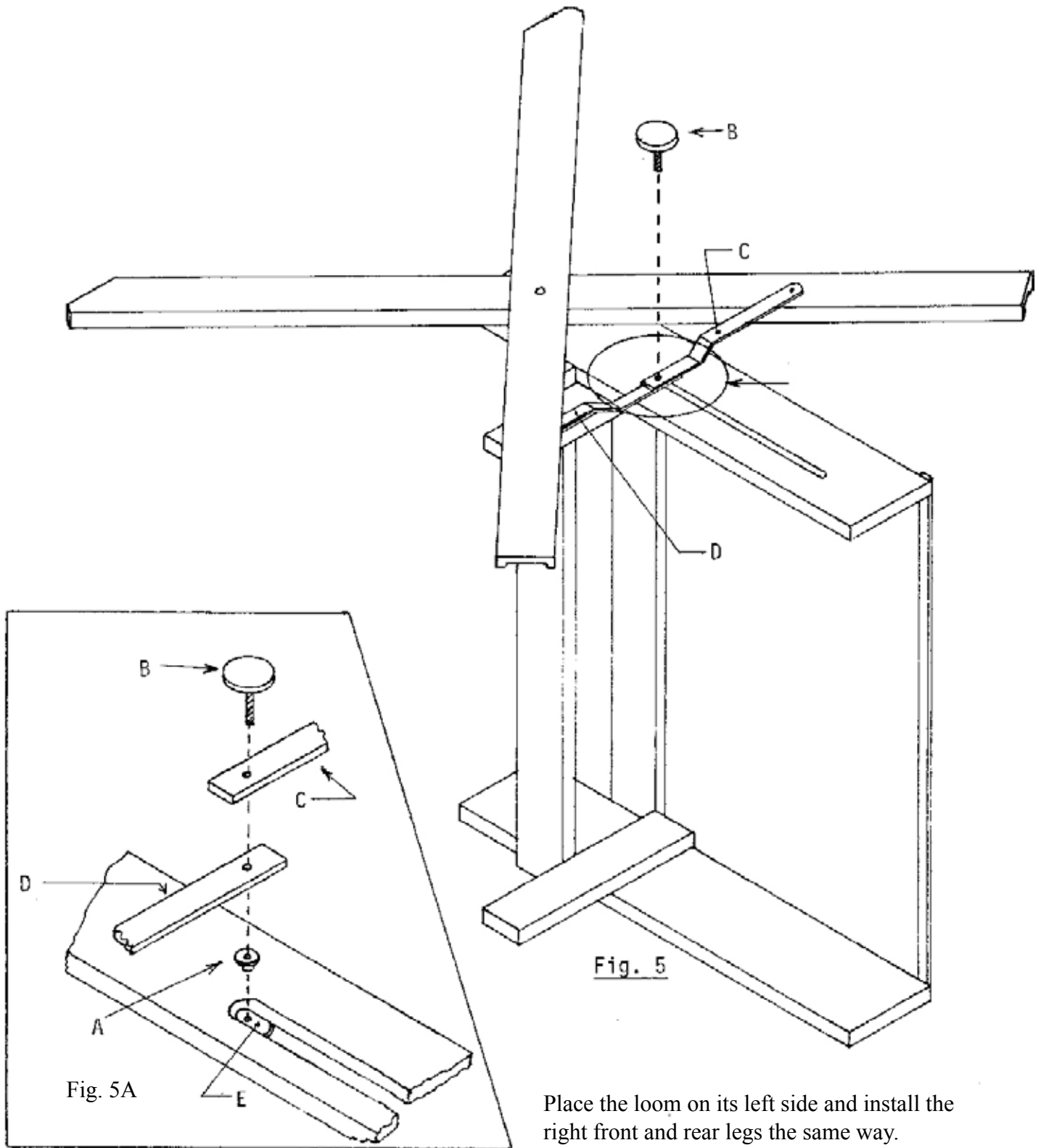

Fig. 5

Fig. 5A

Place the loom on its left side and install the right front and rear legs the same way. Place the loom on its legs.

Fix the three (3) treadle blocks A to the treadle cross-member B with 2" (50mm) round-headed screws No. 14 (fig. 6).

Note: Do not overtighten so blocks can move.

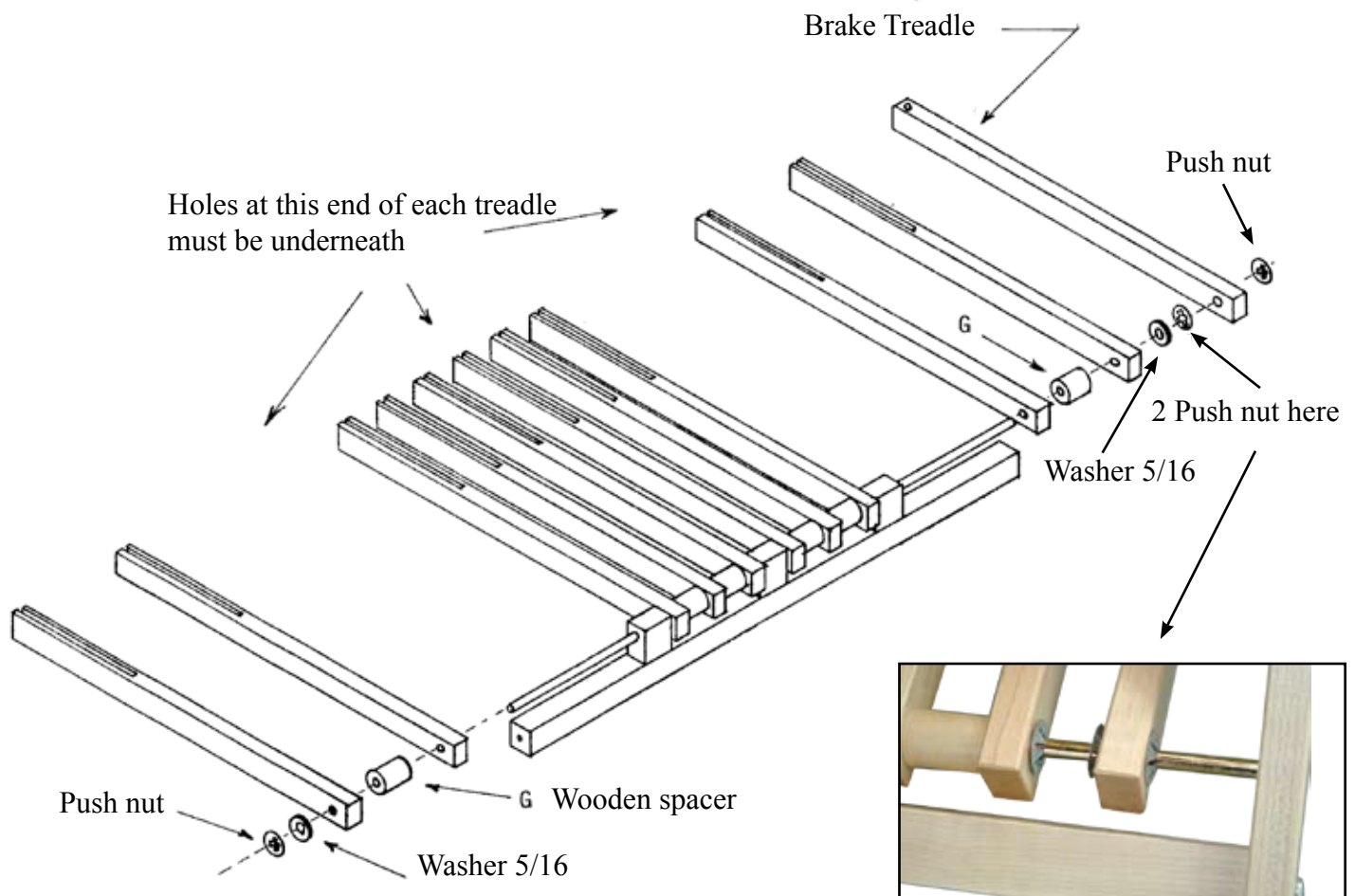
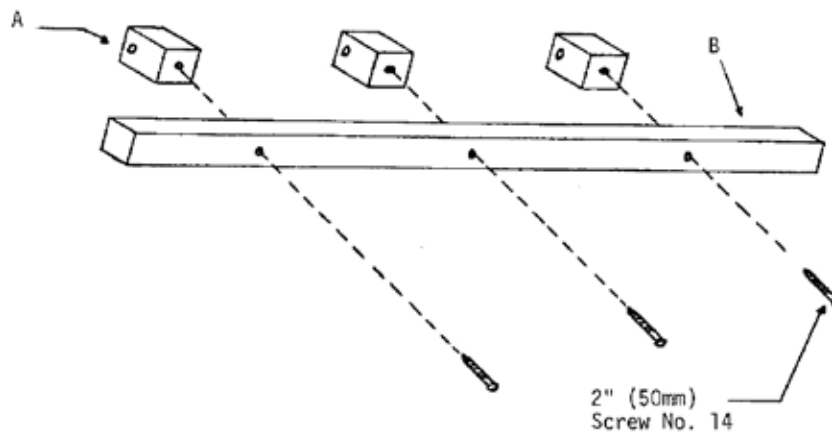

Assemble the treadle set. The brake treadle must be on the right side.

Put one push nut on the left side of treadle no 10 and one after the washer on the right side of treadle no. 1. Put one push nut on each side of the treadle brake to fix it in the middle of the space between treadle No. 1 and the frame post.

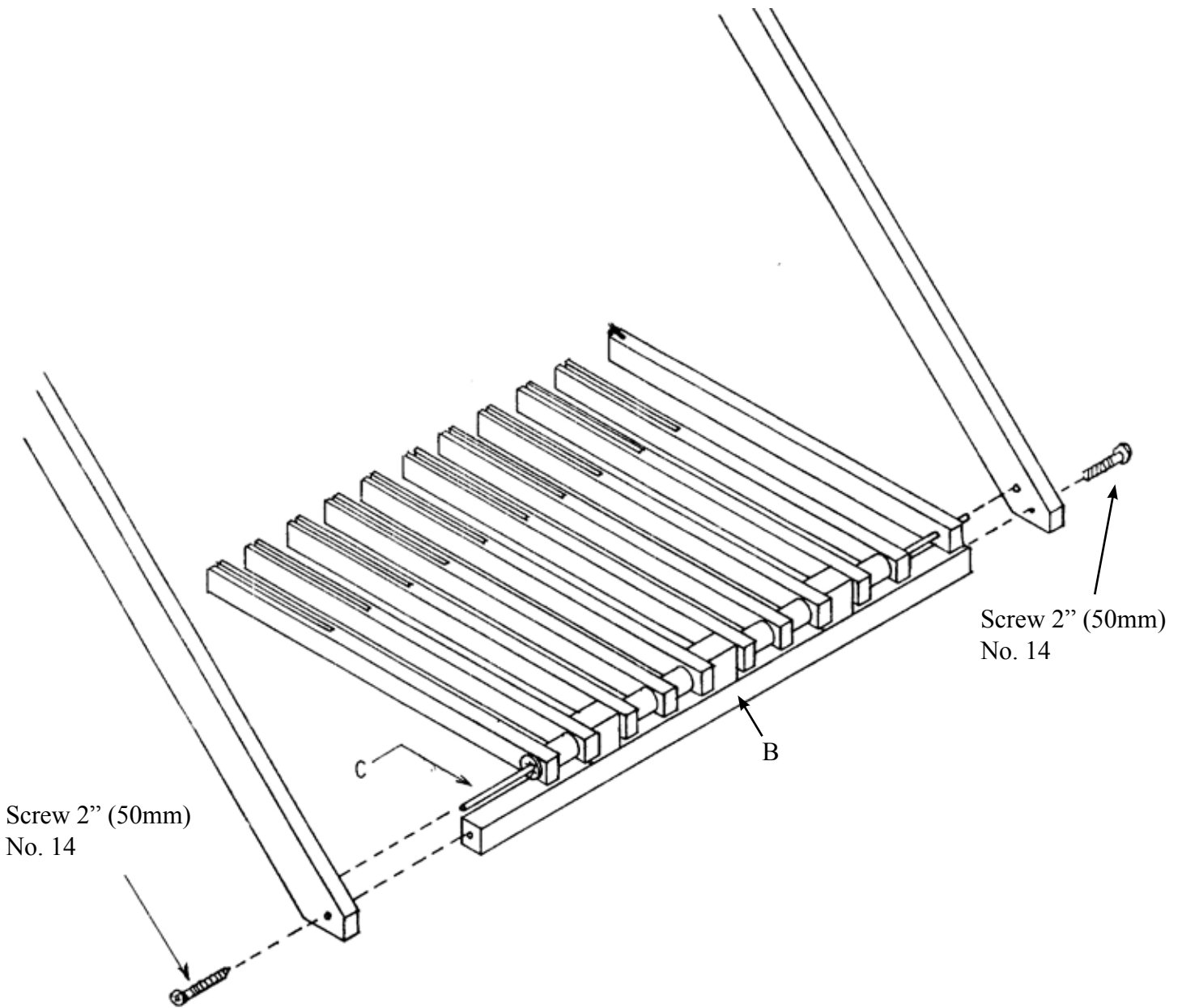

Place the treadle set between the two (2) front legs by spreading them out slightly, so that the ends of the treadle rod C fit between the legs.

Fix the treadle cross-member B with two 2" (50mm) round-headed screws No. 14.

Brake treadle

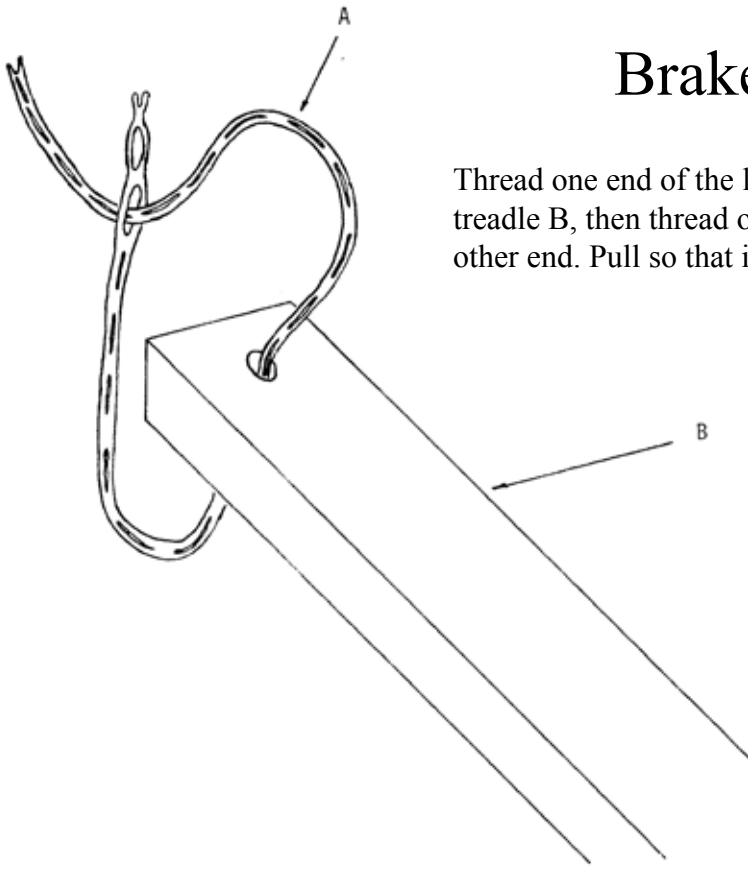

Thread one end of the loop brake cord A into the hole of the brake treadle B, then thread one end of this cord into the second loop of the other end. Pull so that it makes a knot.

Fig. 15

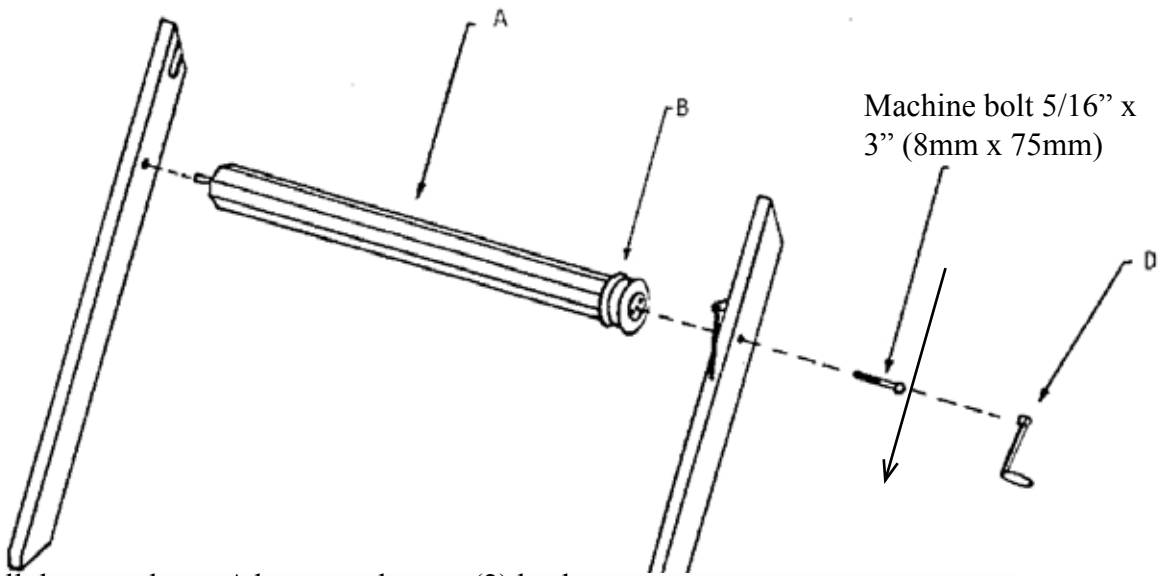

Install the warp beam A between the two (2) back posts
Screw a 5/16" x 3" (8mm x 75mm) machine bolt into the brake drum B.
Use the crank D to tighten the bolt firmly.



Unroll (unpack) the brake cable.
Turn clockwise 3 times around the brake drum starting at the top.

Join the end of the cable to the back “S” hook of the brake lever.

Join the brake loop cord to the Back “S” hook using the best possible loop so the brake treadle will be at the desired height.



Join the front “S” hook of the brake lever to the brake spring loop cord so the tension on the spring will be high enough to lock the warp beam while weaving.

The warp beam should turn with some friction clockwise (while standing at the right side of the loom near the brake system) and this is the warping rotation. However, you should always release the tension on the friction brake system by disconnecting the spring from the brake lever (S hook) when you are warping the loom.

To advance the fabric when weaving, depress the brake treadle just enough to release the warp beam. Depressing the brake treadle too far may cause the brake cable to come off the brake drum.

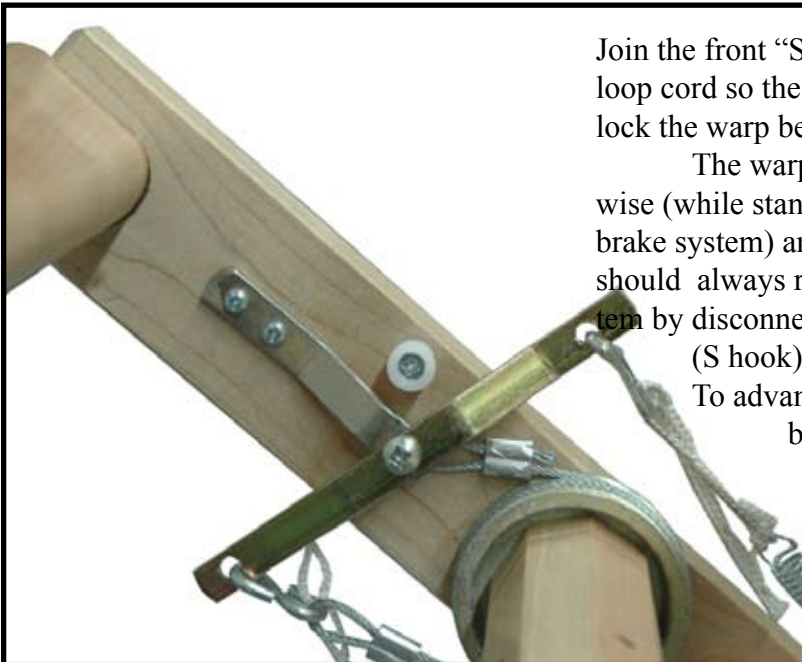

Install the thread beam (29½") A using round-headed screws No. 14, 1½". Install the lower cross-member B (30½") in back of the loom with round-headed screws No. 14, 2".

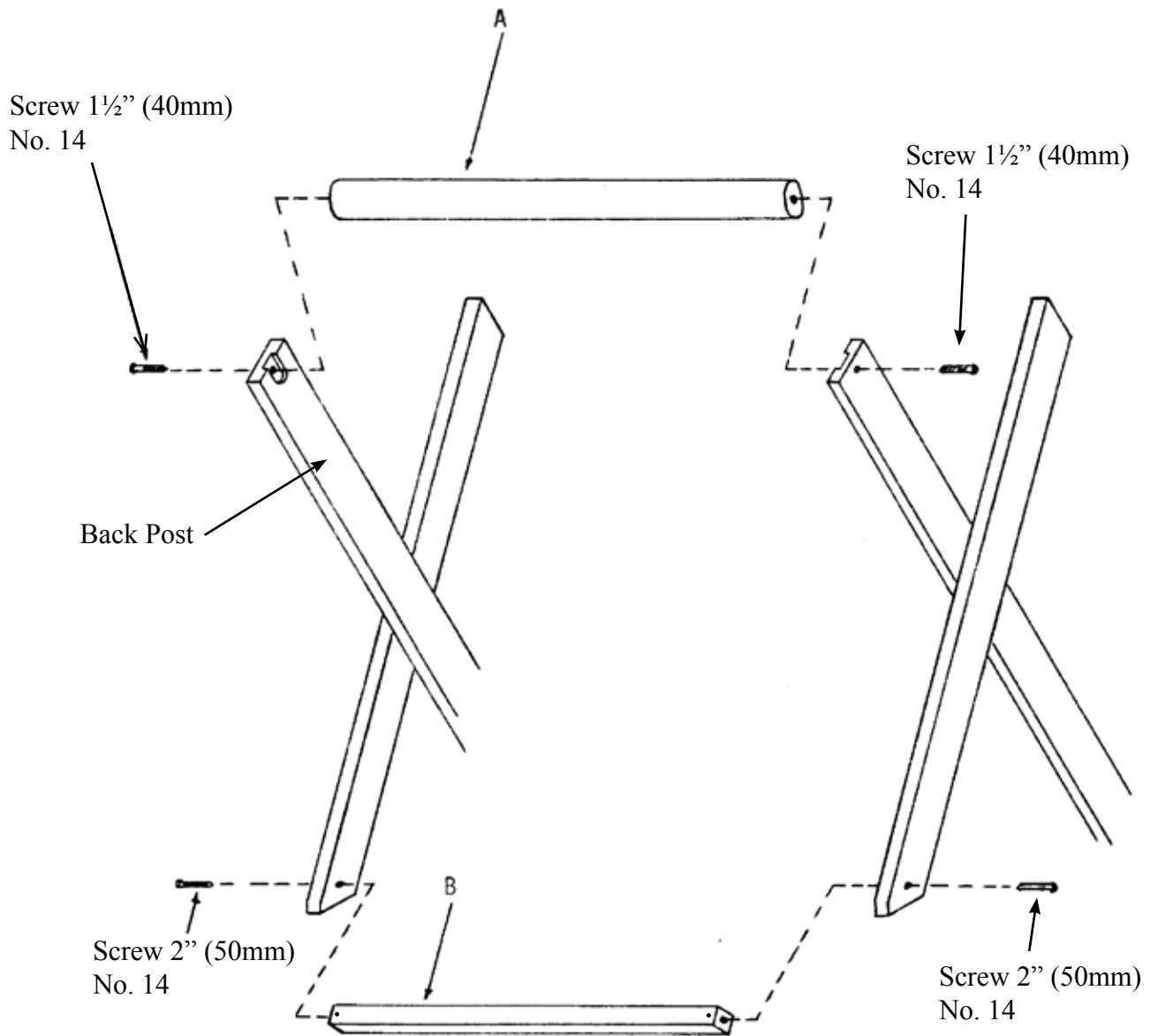
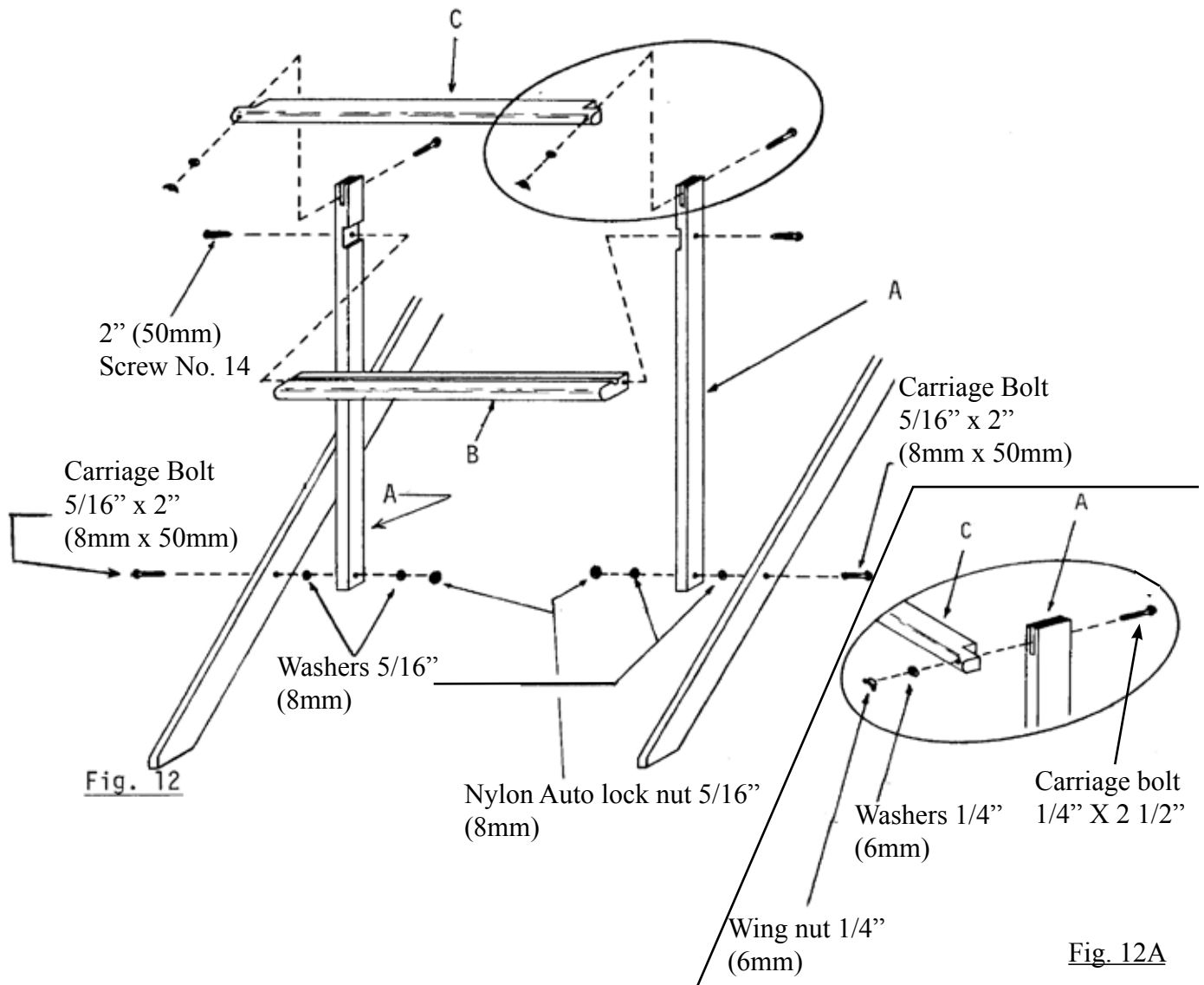

Fig. 11

Fix each of the two (2) batten swords A inside the front legs with a 5/16" x 2" (8mm x 50mm) carriage bolt. Place a steel washer between the sword and the leg. With a hammer, hit on the head of the bolt until the square inside part is in the wood. Put a washer inside and lock it with the nylon auto lock nut 5/16" (8mm) without overtightening it. The swords must move freely.

Fix the batten sley B with two 2" (50mm) round-headed screws No. 14.

Fix the batten handtree C with two 1/4" x 2 1/2" (6mm x 65mm) carriage bolts, two steel washers 1/4" and two wing nuts 1/4" (Fig. 12A).



Place the reed A between the batten handtree B and the batten sley C, and lower the batten handtree.
Tighten the wing nuts.

Using a hammer, insert a batten stopper D (round piece of wood) into each of the two (2) swords E.

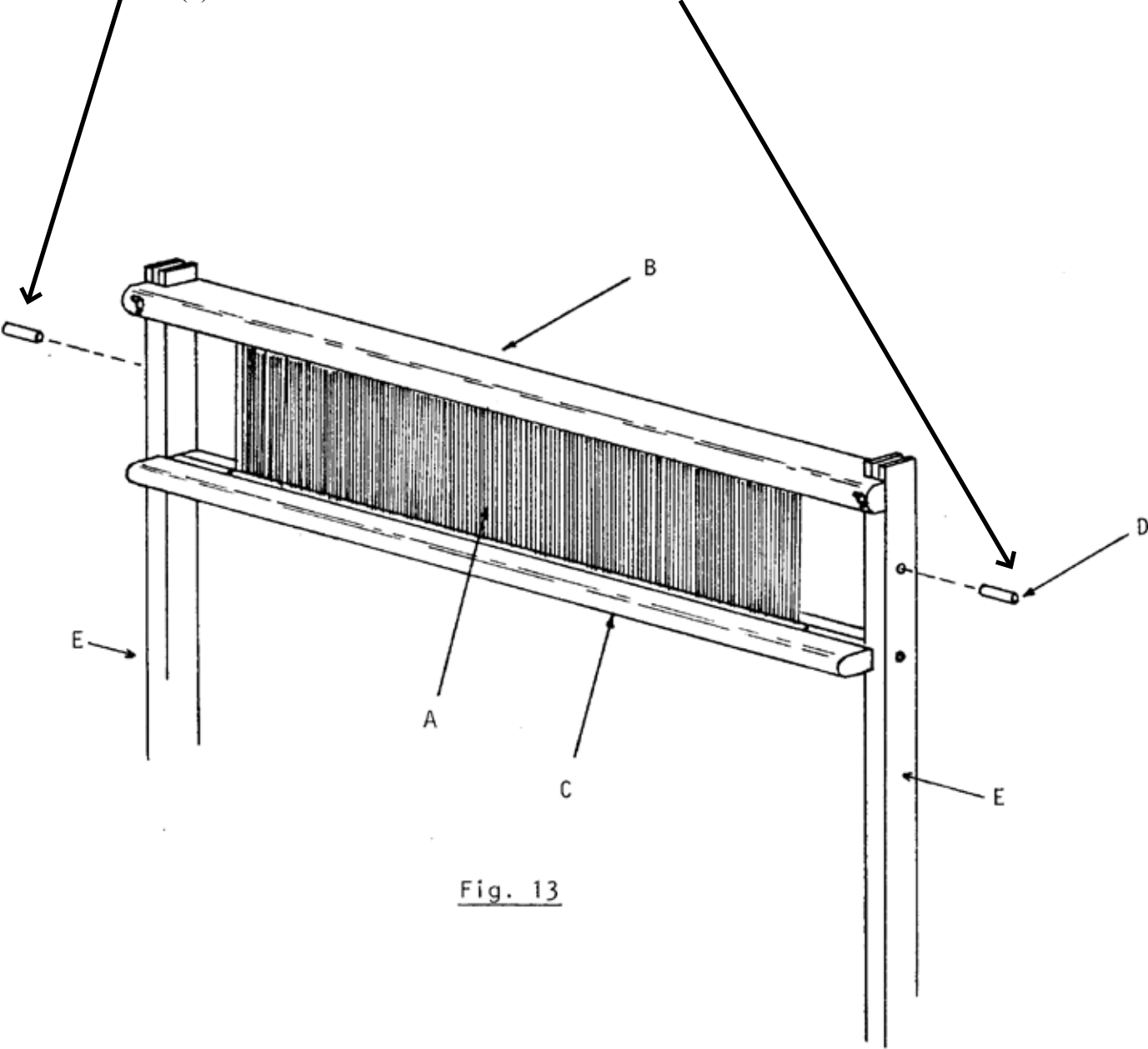

Fig. 13

Install the breast beam A with two round-headed screws 1½" (40mm) No. 14.
Make sure that the hole for the eyescrew is on the right side, more instruction on next page.

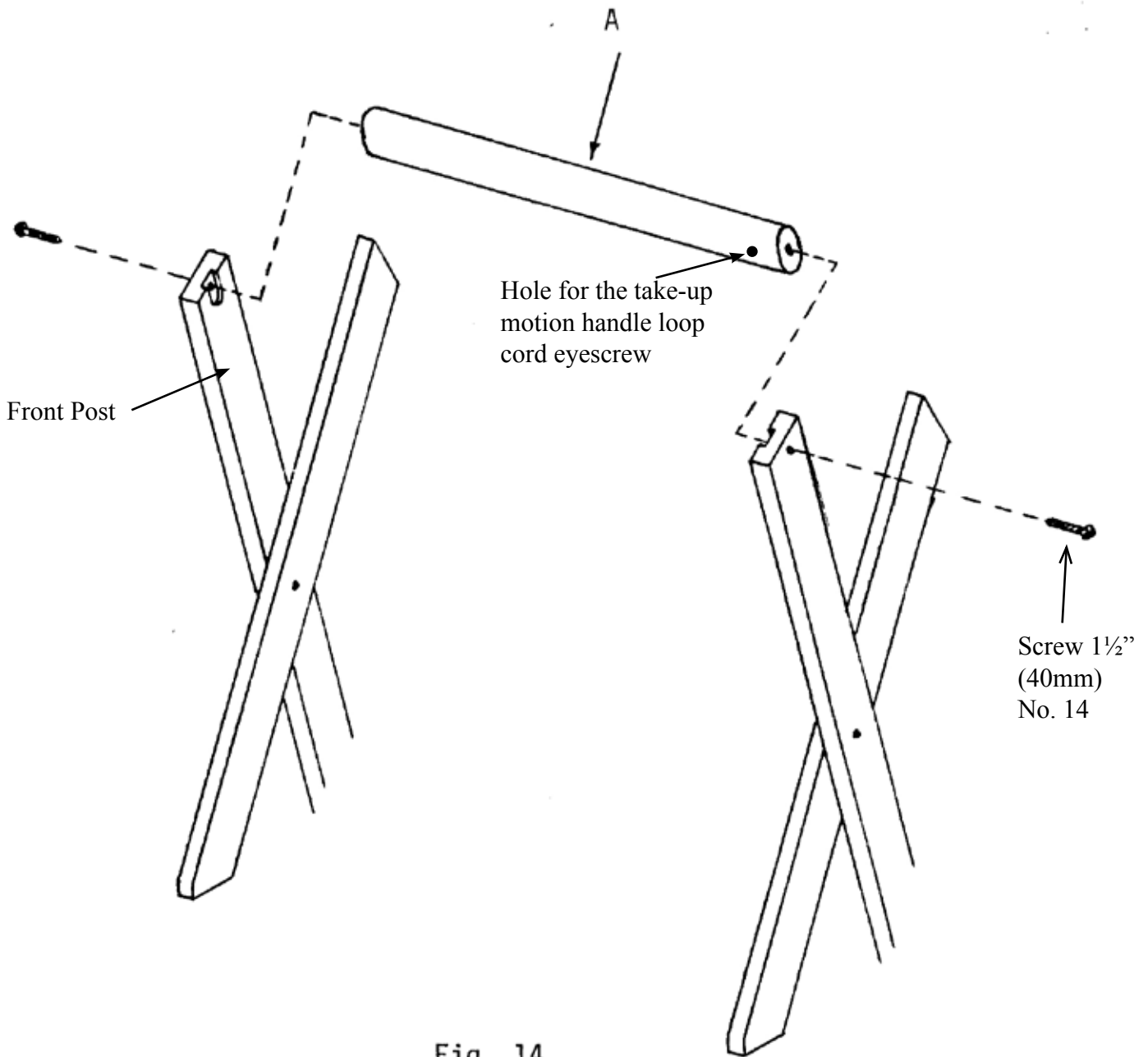
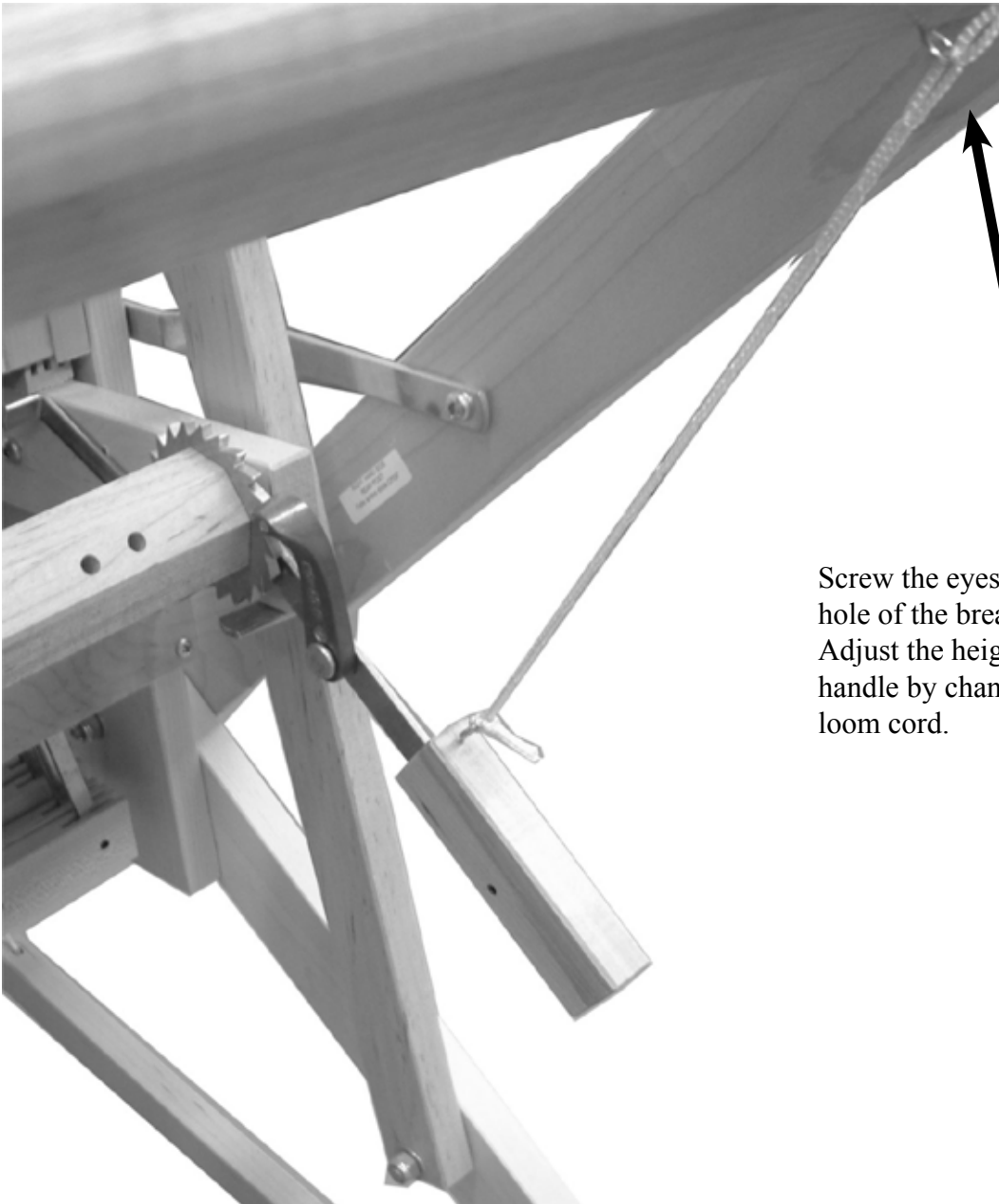
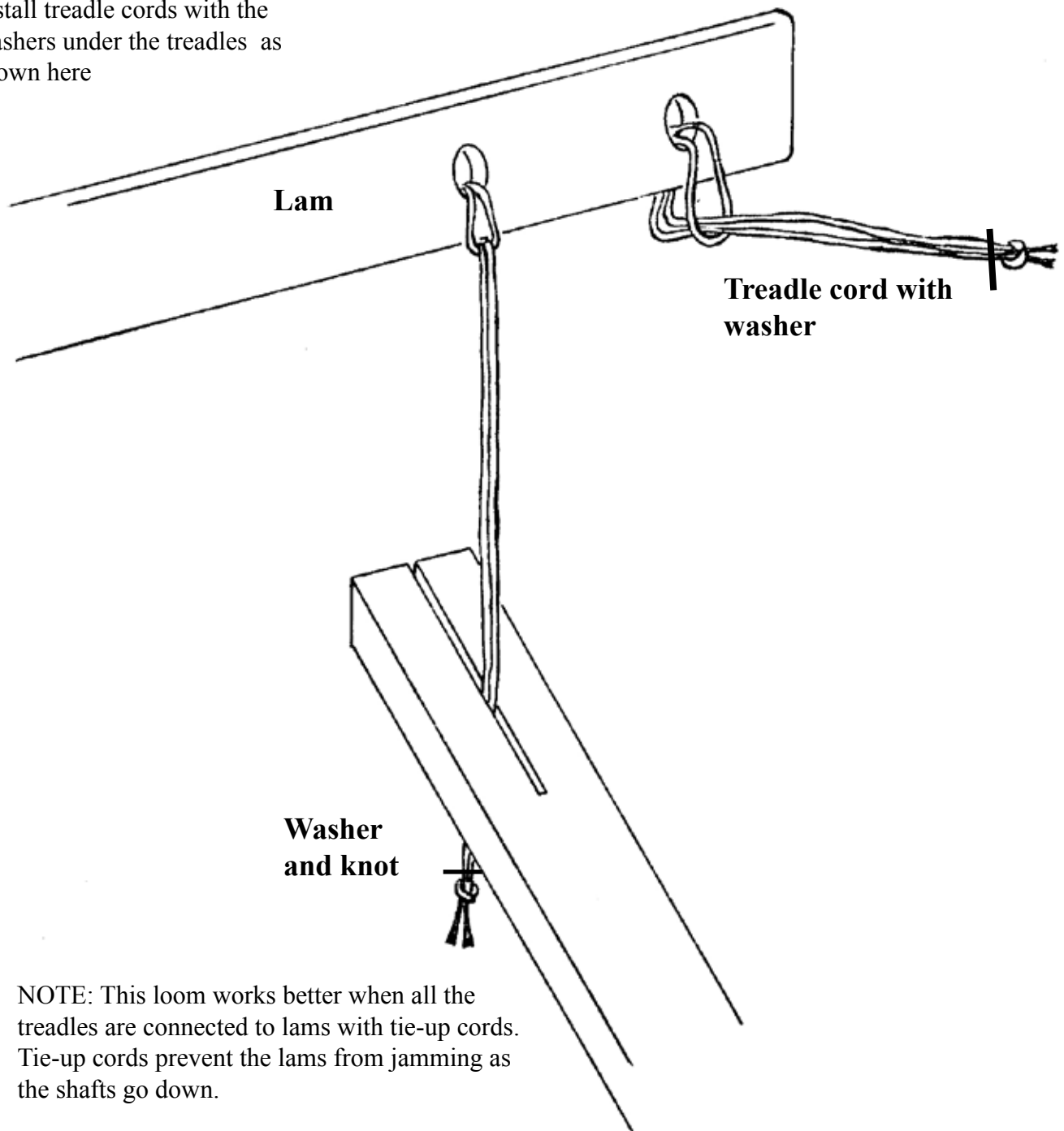

Fig. 14



Screw the eyescrew in to the pre-drilled hole of the breast beam.
Adjust the height of the take-up motion handle by changing the length of the loom cord.

Install treadle cords with the washers under the treadles as shown here



NOTE: This loom works better when all the treadles are connected to lams with tie-up cords. Tie-up cords prevent the lams from jamming as the shafts go down.

Following each tie-up, close the gate at the end of each treadle.

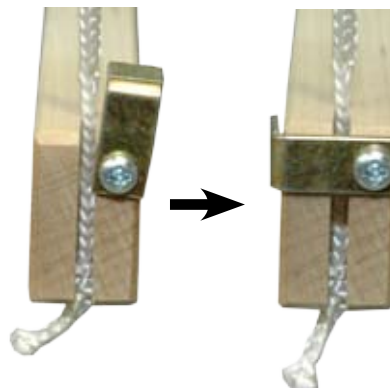

SPRING KIT

When more than 6 treadles are connected to the lams, the weight of the treadles can lift the shaft frames up or make the movement down very difficult.

To correct this you will have to install springs that will support the weight of each treadle.

Unscrew the 2 lower screws from the back jack box.

Put the Wooden board with the 3 eye screws on top of the jack box board and screw it in using the same screws.

Insert the metal rod into the eyelets and place the springs between them as illustrated below.

Slide the rod until the notch is at the first eyescrew .

Make a loop cord knot so the length of the spring with the loop cord will hold the weight of the treadle.

Slide the loop cord end (knot) under each treadle.

The length of the treadle spring loop cord has been preset but it is possible that you will have to change the position of the knot if the cord becomes too loose or if the treadle is too high.

It is preferable to always have a small amount of tension on the treadle spring when the treadle is in the up position.

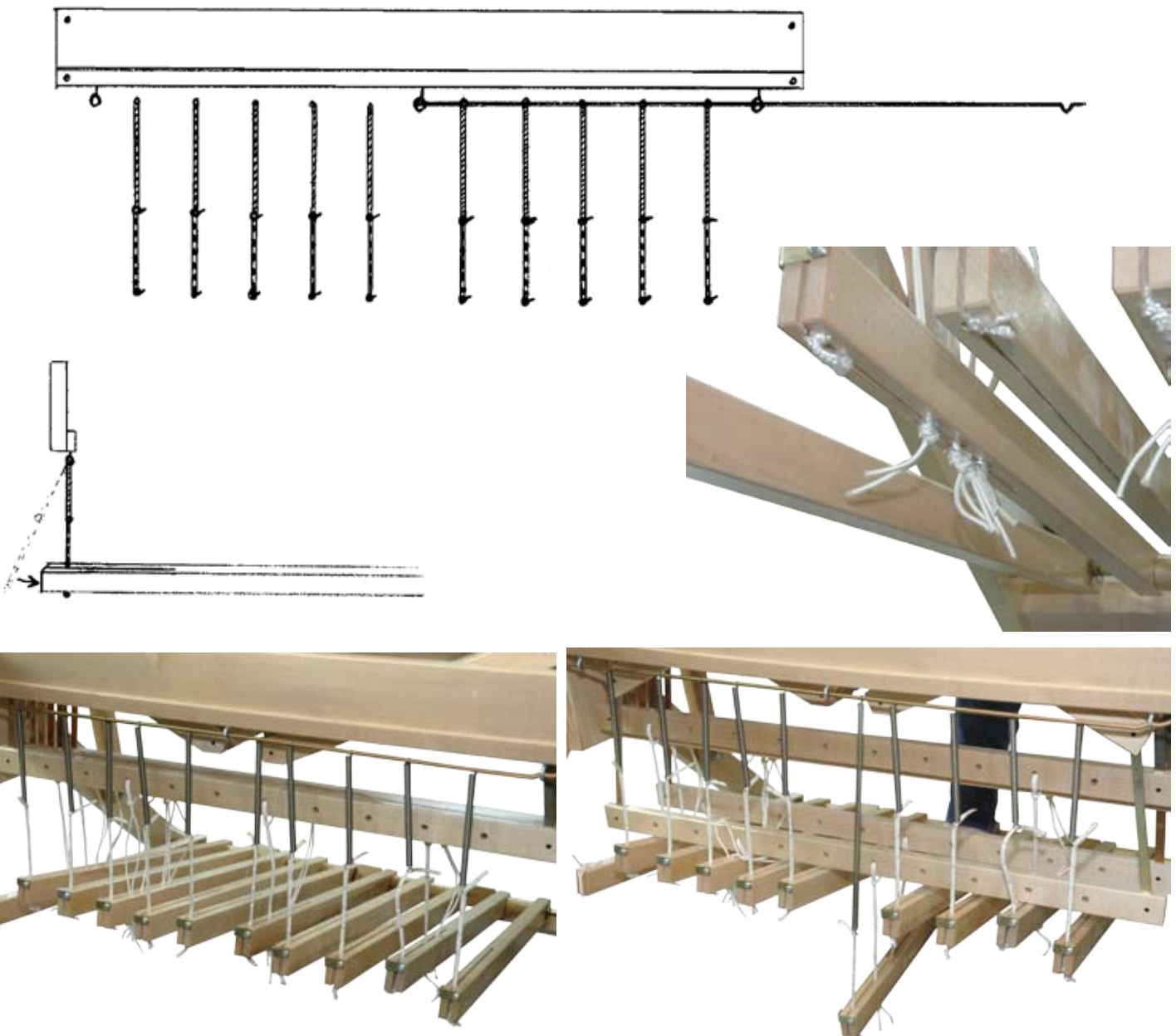

BEAMING

On this loom, beam sticks and cords have to be installed in place of the usual apron.

Thread a 10 yard (9.2m) nylon cord through the third set of holes of the warp beam.

Then thread the two cord ends through the corresponding holes of the beam stick

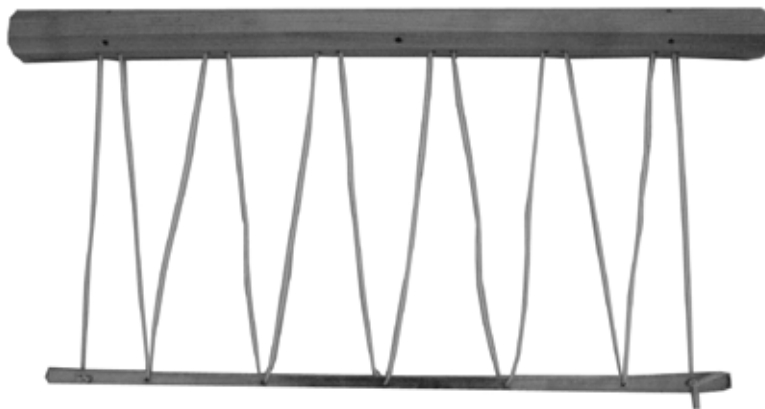
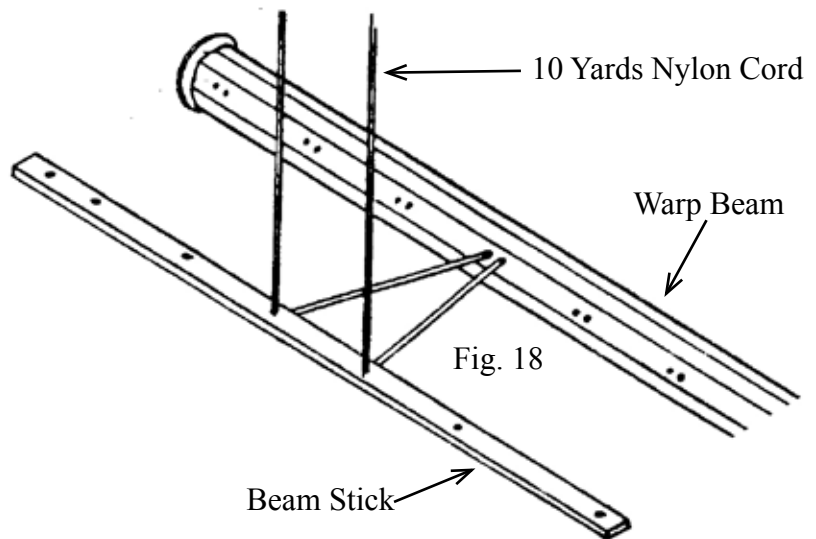
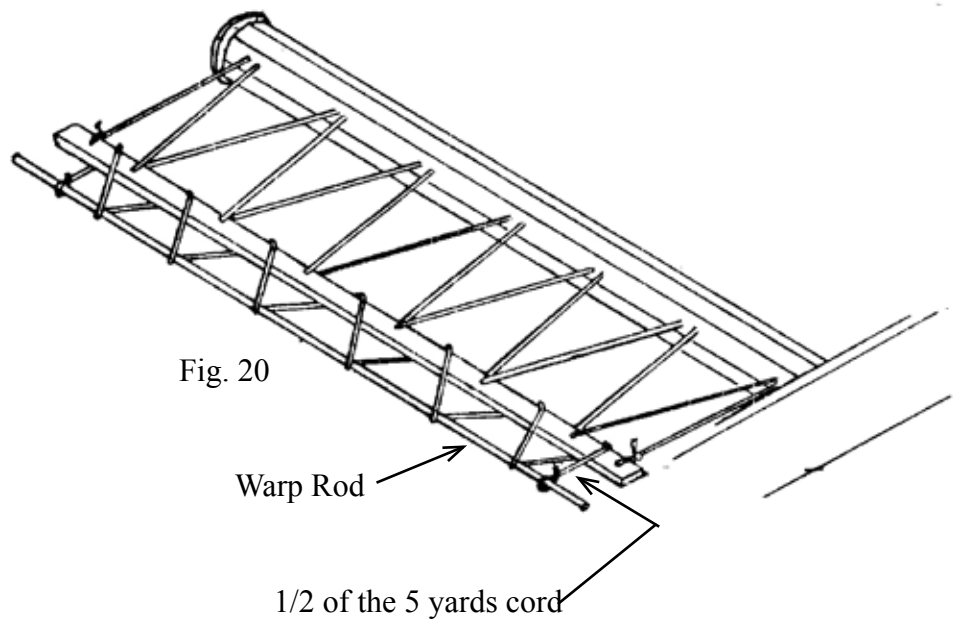

Fig. 19

Continue threading the cord through the warp beam and the beam stick.

Knot the cord at each end of the beam stick.

Adjust the cord so that the tension and the length are the same for the whole width of the loom.



Cut the 5 yard (4.5m) cord in half. Use one half of the cord to lace the beam stick to the warp rod.

Repeat the same operation for the cloth beam.

To install the heddles you can just bend the heddle supports .

To remove the shaft frames you first have to unscrew the top nut of the jack pin. It is important to leave the bottom nut as it is.

Then pull up the shaft frame from the castle.

We strongly recommend that you have those nuts installed at all times.

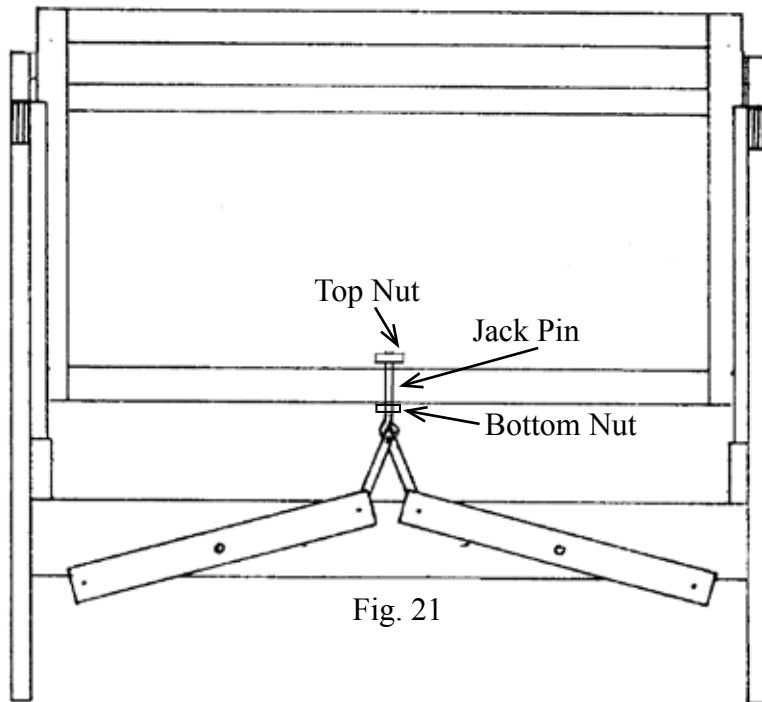

Fig. 21

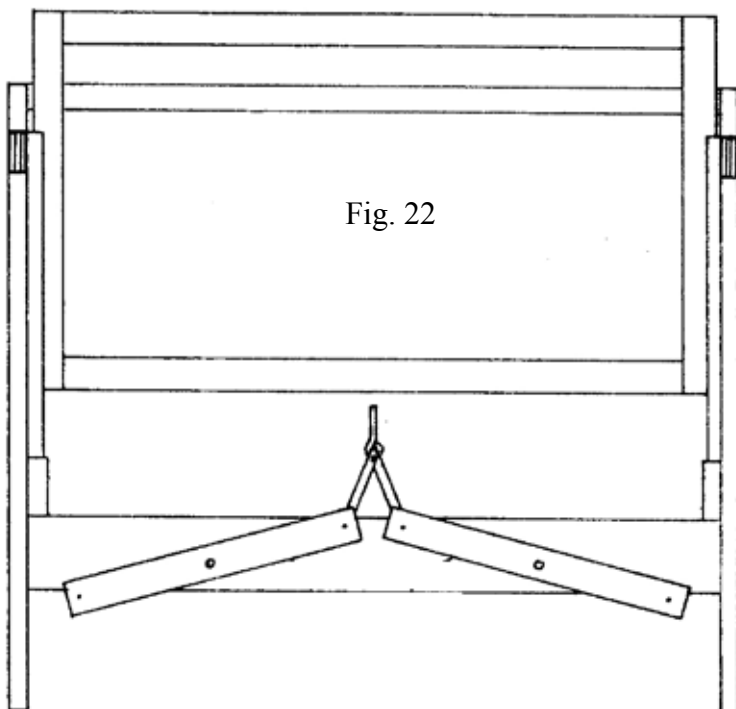

Fig. 22

TO INSTALL HEDDLES:

Disconnect the center of both heddle supports of a shaft frame and take it out of the end frame by bending it.

For more information, see the book supplied with the loom "Warp & Weave".

WHEEL KIT FOR THE COMPACT LOOM



INSTRUCTIONS:

As you can see the blocks sit on the back cross member and attach to it with 2 screws #8, 2"

Insert the carriage bolts from the outside of the loom.
Hammer in and affix them using the washers and wing nuts.

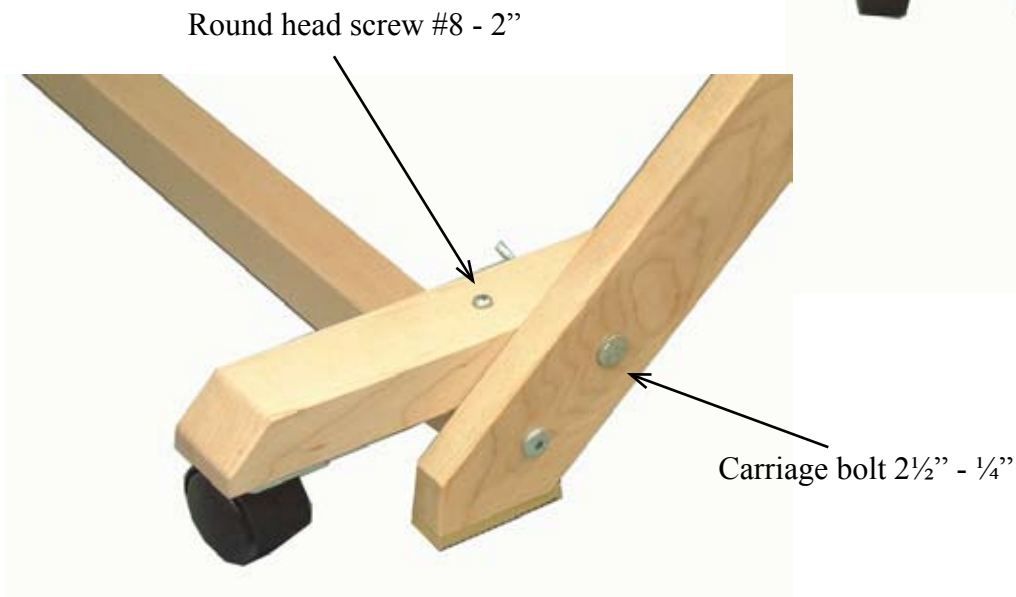
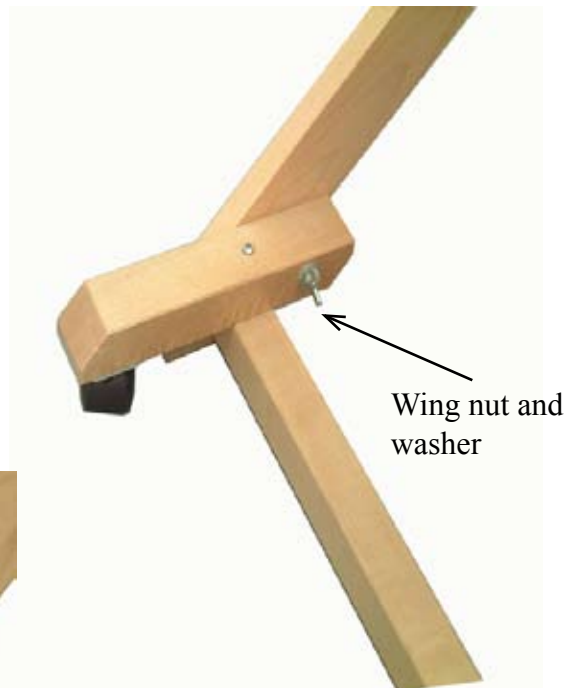

Warp beam advance control system

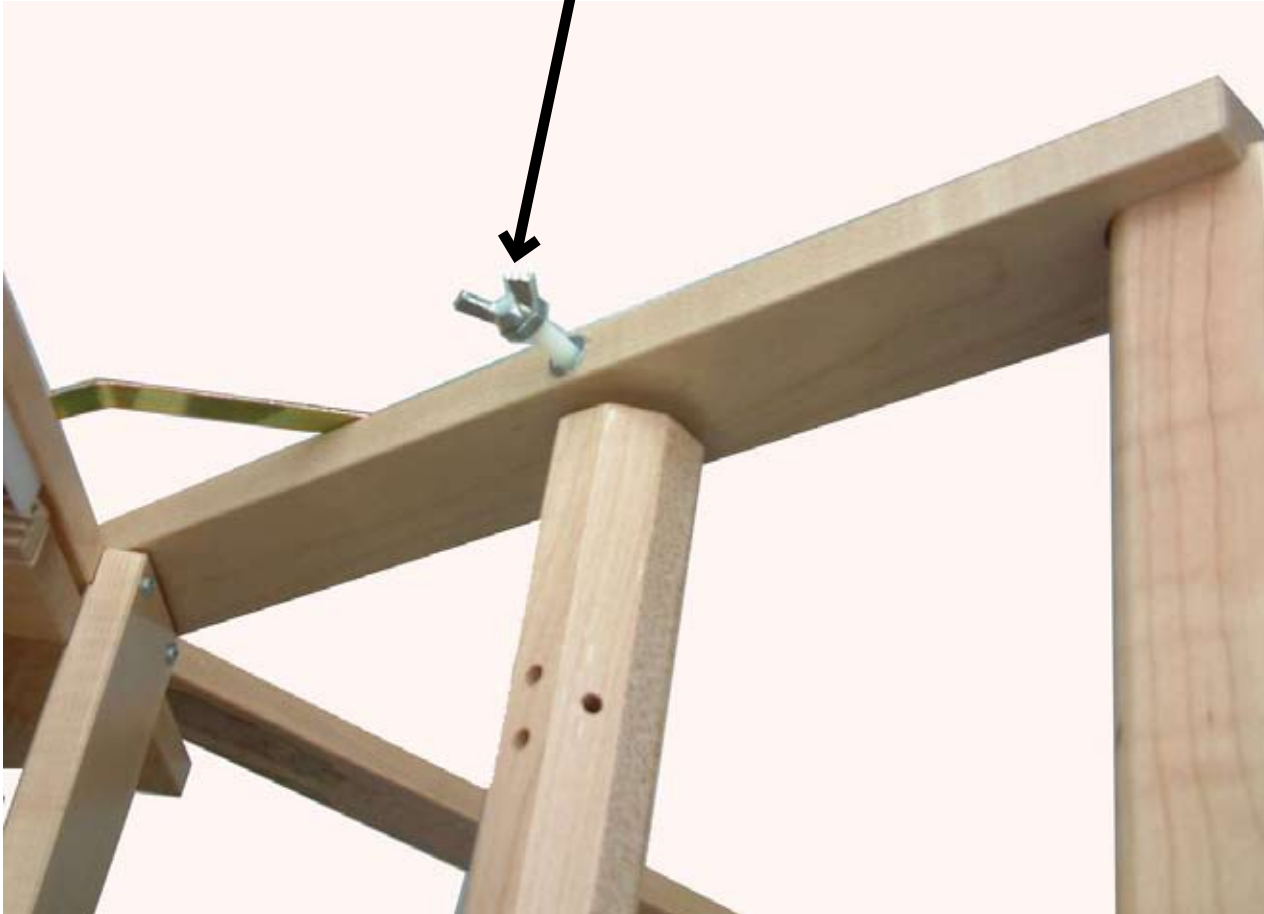

Install the Warp beam advance control system.

This system will eliminate excessive warp yarn advance when releasing the brake system at cloth take-up.

This friction system is adjustable and **have to be released when winding the warp on.**

Just screw the wing nut with nylon bolt in the pre-install metal indert of the left back post.

Screw in to Increase the friction or unscrew it to release.

To fold the loom, release the tension by pressing the brake treadle, then loosen the plastic handles on each side of the loom and pull these upward. Tighten the handles.
The loom can fold even with fabric on it.

MAINTENANCE:

In order to get the maximum efficiency from your loom, we recommend you periodically spray a lubricant (silicone) on the plastic slides on each side of the loom.

We at Leclerc encourage Weaver feedback on this and all our products. Please send your comments to Leclerc Loom Co.

HAPPY WEAVING

