

Leclerc Looms

Since 1876



COLONIAL V2 8 & 12s Jack type Back Hinge Treadle

1573 Savoie
C. P. 4 Plessisville, Qc.
G6L 2Y6
TEL: 819-362-7207
FAX: 819-362-2045
www.leclerclooms.com
info@leclerclooms.com

	8s	12s
45"	1051-0082	1051-0122
60"	1052-0082	1052-0122

On receiving the loom, unpack and lay out the loom components. Do NOT discard any packing material until all parts are inventoried.

Check the parts received against the parts list on pages #2 to #7 of the assembly instructions. Report any discrepancies to Leclerc immediately.

To assemble this loom, a minimum of 2 people are needed but it is recommended you use 3.



Loom Prepared by: _____

Inspected by: _____

Date: _____

PARTS LIST

1 right-hand side



1 left-hand side



Note for Leclerc in French :

Faire les avant trous pour le frein d'ensouple



Faire les petit trous dans les montants pour les baguettes d'encroix.

Ne pas oublier l'espaceur brun pour le crochet vertical de la patte du pédalier arrière.

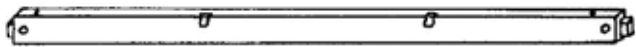

2 upper cross-members



8 or 12 floating lams



1 apron



1 cloth take-up motion handle



2 lam separators

Note for Leclerc Looms only:
Ensemble marmoussets avec
les rondelles.



1 Jack assembly (8 or 12 jacks)

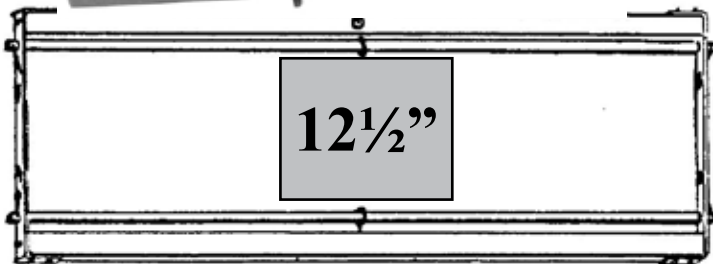

8 or 12 shaft frames

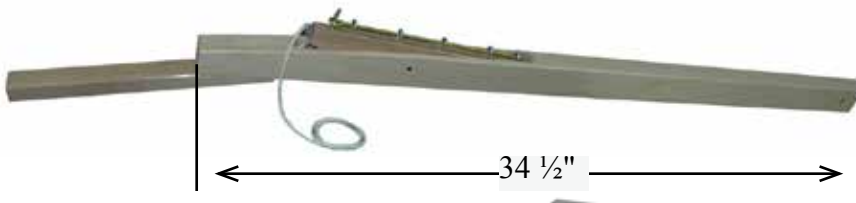

10 or 14 treadles

Note for Leclerc
Looms only:
Avec arrêt de bas-
cule sous la pédale.



3 treadle supports 3/16" x 6 1/16



1 treadle set rod with push nut
(40" / 12S - 28.75 / 8S)



1 Push nut

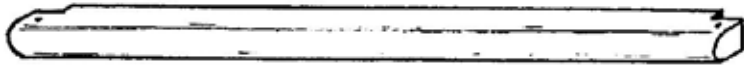

2 breast beams

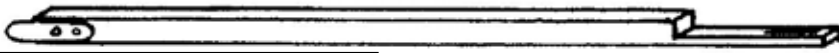

1 left sword

Note for Leclerc Looms only:
Ferrure ajustées à 3"

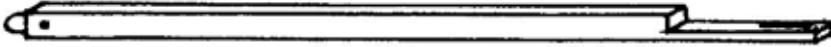

1 right sword



1 back board of the lam box

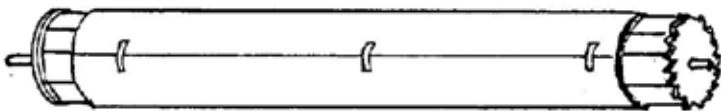

1 cloth beam

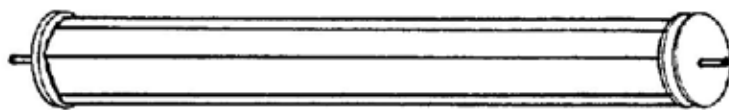

1 warp beam



1 batten handtree



1 batten sley with shuttle race

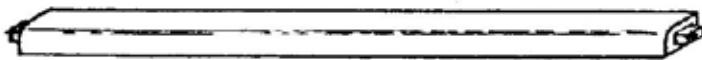

1 middle cross-member
1 front cross-member

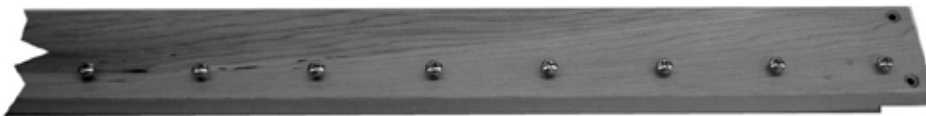

1 front board of the lam box

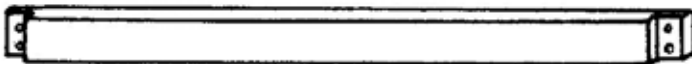

1 lower-back board connecting back posts

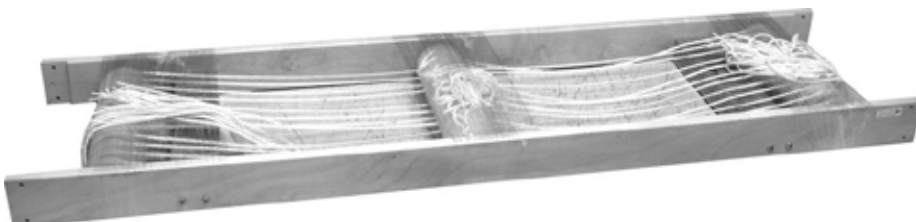

1 upper shaft frame control unit



1 crank (back beam)

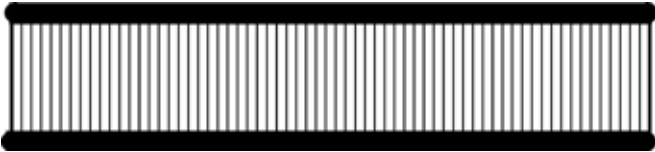

1 reed



2 lease sticks



4 warp rods



10 or 14 treadle hooks 12" with pegs

Note for Leclerc Looms only:
Marques noir sur
les cordes



5 sets or 8 sets treadle cords 8.5"



10 or 14 loop cords 18" for rocker piece



10 ou 14 springs with clip and loop cord

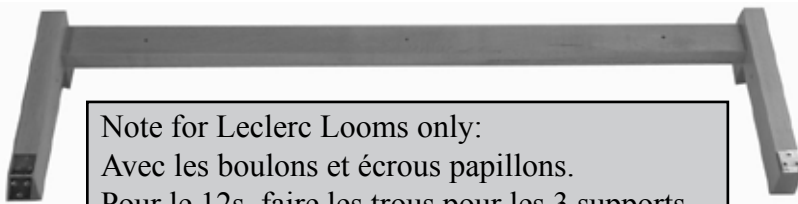

Note for Leclerc Looms only:
Avec les boulons et écrous papillons.
Pour le 12s, faire les trous pour les 3 supports
de pédaliers.
Pour le 8s faire les trous pour le 8 et 12s.

1 back hinge treadle support



1 back hinge treadle separator



3 screwdrivers (red, green and black)



1 adjustable wrench

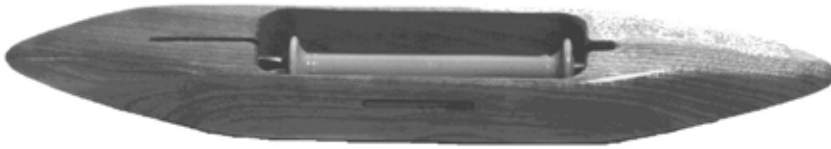

1 boat shuttle



12 plastic bobbins



1 Reed hook (long)



2 pk of cord (5 yd each)



2 Unvarnished wooden bars with black stripe app. 15" long



2000 heddles (45" loom)
2500 heddles (60" loom)

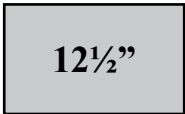

1 warp beam advance control system



Machine bolts
8X - 3/8" x 5"

0

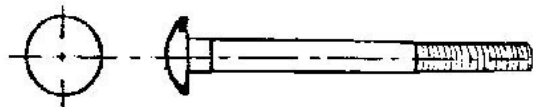

Carriage bolts
2X - 5/16" x 2 1/4" (swords)
4X - 5/16" x 2 1/2" (Beater)
3X - 5/16" x 4 1/2" (Treadle set)

1"



9X - 5/16"
4X - 9/16"
8X - 3/8"



HEXAGON NUTS
2X- Nylon auto lock 5/16"

2"

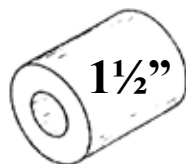

Wooden spacers
1 1/2" 8 or 12 wood spacers for the treadle set



SQUARE NUTS
8 3/8" (10 mm)
5 5/16" (8mm)

3"



Wing nuts
5X - 5/16" (8 mm)

4"



Round head screws
8X - #12 x 1 1/2"
4X - #12 x 1 1/2"
4X - #14 x 2 1/2"



16 or 24 short cords 24" (Shaft frame to Jacks side connection)

Note for Leclerc Looms only:
CORDES AVEC DES MARQUES NOIR



Flat head screws
6X - #8 X 1" (Back post)
4X - #12 x 1.5" (Back board)



2X eye screws
(lease sticks)



1 instruction Video showing all stages of installation. (OLD type Colonial)



Tacks for canvas

WARP AND WEAVE



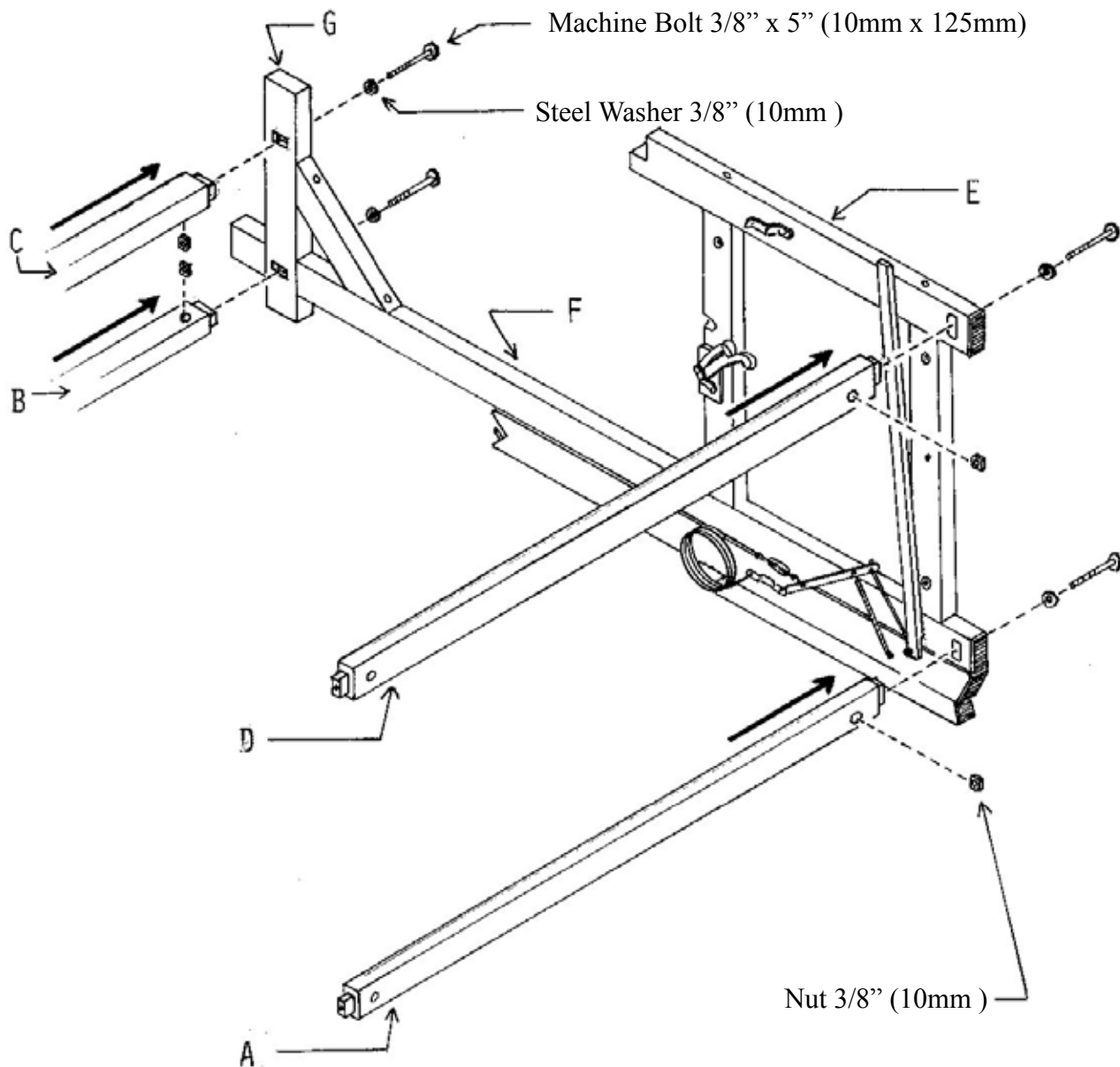

CROSS-MEMBER ASSEMBLY

- 1) Insert a tenon of the lower middle cross-member A into the lower mortise of the middle post F.
note: the middle cross-member A does not have any holes drilled through it or notches.
- 2) Insert a tenon of the upper back cross-member B into the back mortise of batten support G.
note: the upper back cross-member B is one of the two cross-members with two notches. The notches must be on the top (when the loom is upright).
- 3) Insert a tenon of the upper front cross-member C into the front mortise of batten support G.
note: cross member with notches. The notches must be above and face the notches of cross-member B.
- 4) Insert a tenon of treadle set cross-member D into the mortise of front post E.
note: the treadle set cross-member D does not have any holes drilled through it or notches.

Cross-members A, B, C and D must be affixed with 3/8" x 5" (10mm x 125mm) machine bolts, steel washers and 3/8" square nuts.

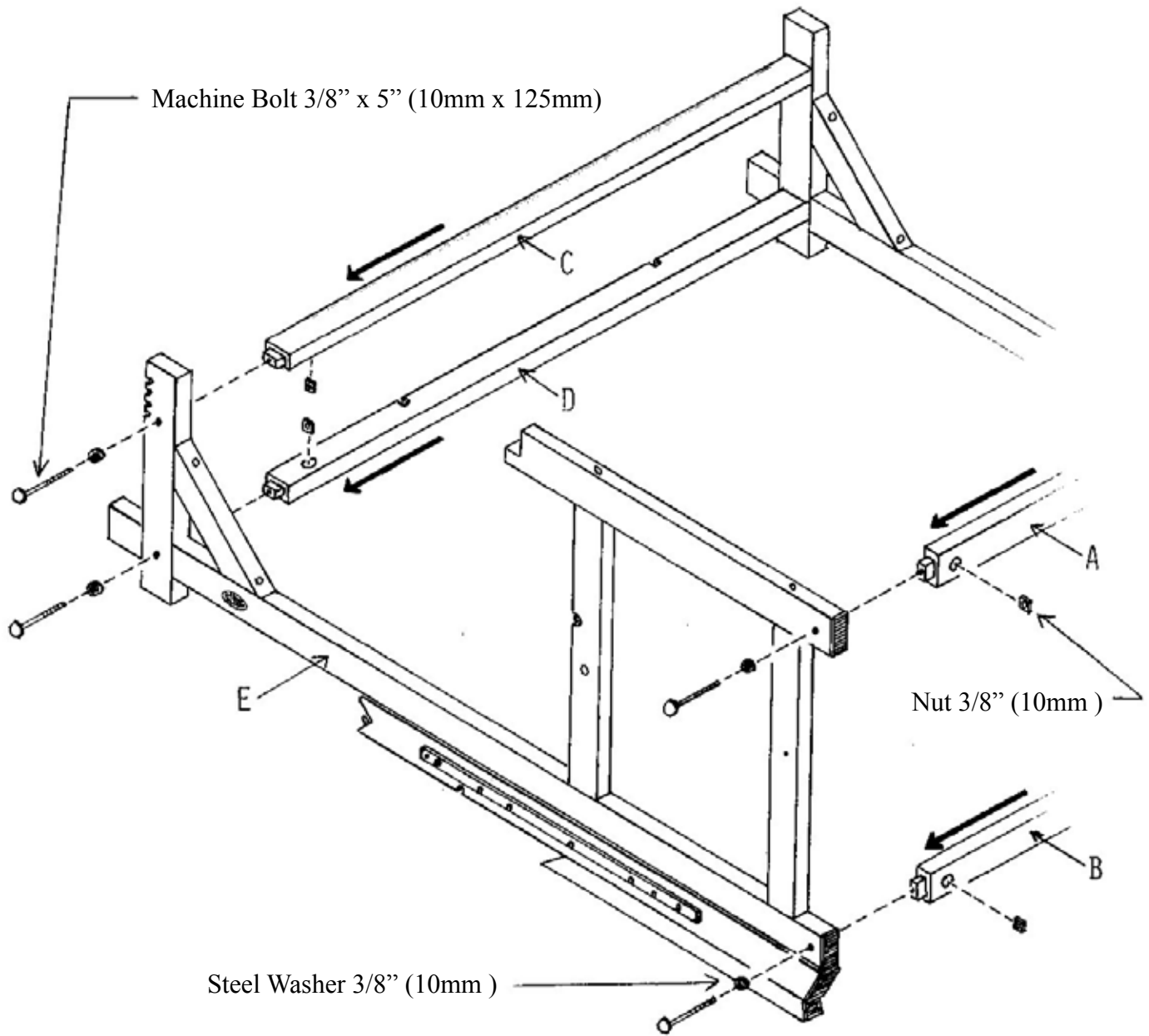

Insert the tenons at the other end of the cross-members A, B, C and D into the mortises of left-hand side E of the loom.

ATTENTION: Application of soap to the screws will make their insertion easier.

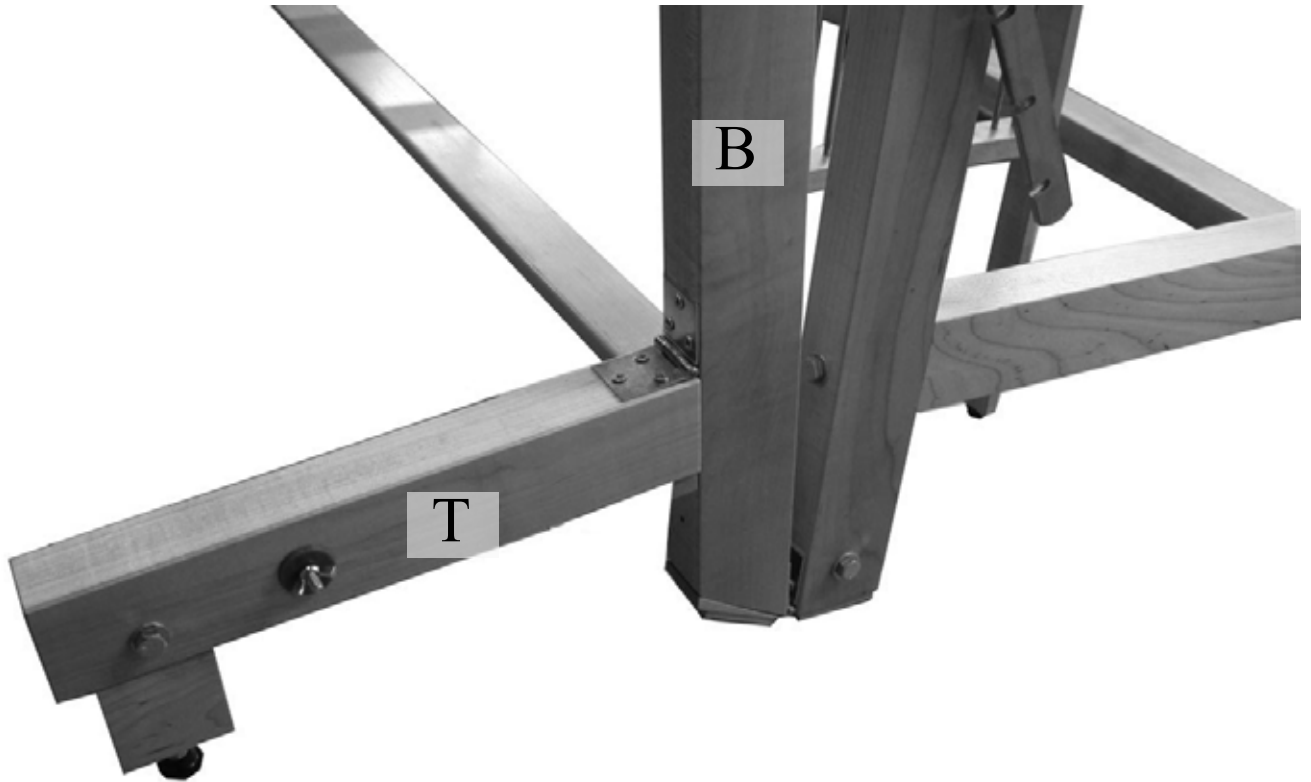

Partly fold the 2 back post (B) both back and using six #8, 1" flat-headed screws, affix the back hinge treadle support assembly (T) to the back post of the loom.



Insert the tenons of the treadle cross-members (C) into the mortises of the left-hand and right hand sides (T).

Assemble it Use 3/8" X 5" (10 mm X 125 mm) machine bolts, 3/8" (10 mm) steel washers, and square nuts.



Affix the connecting hook (P1) to the back post and the hook (P2) to the treadle support

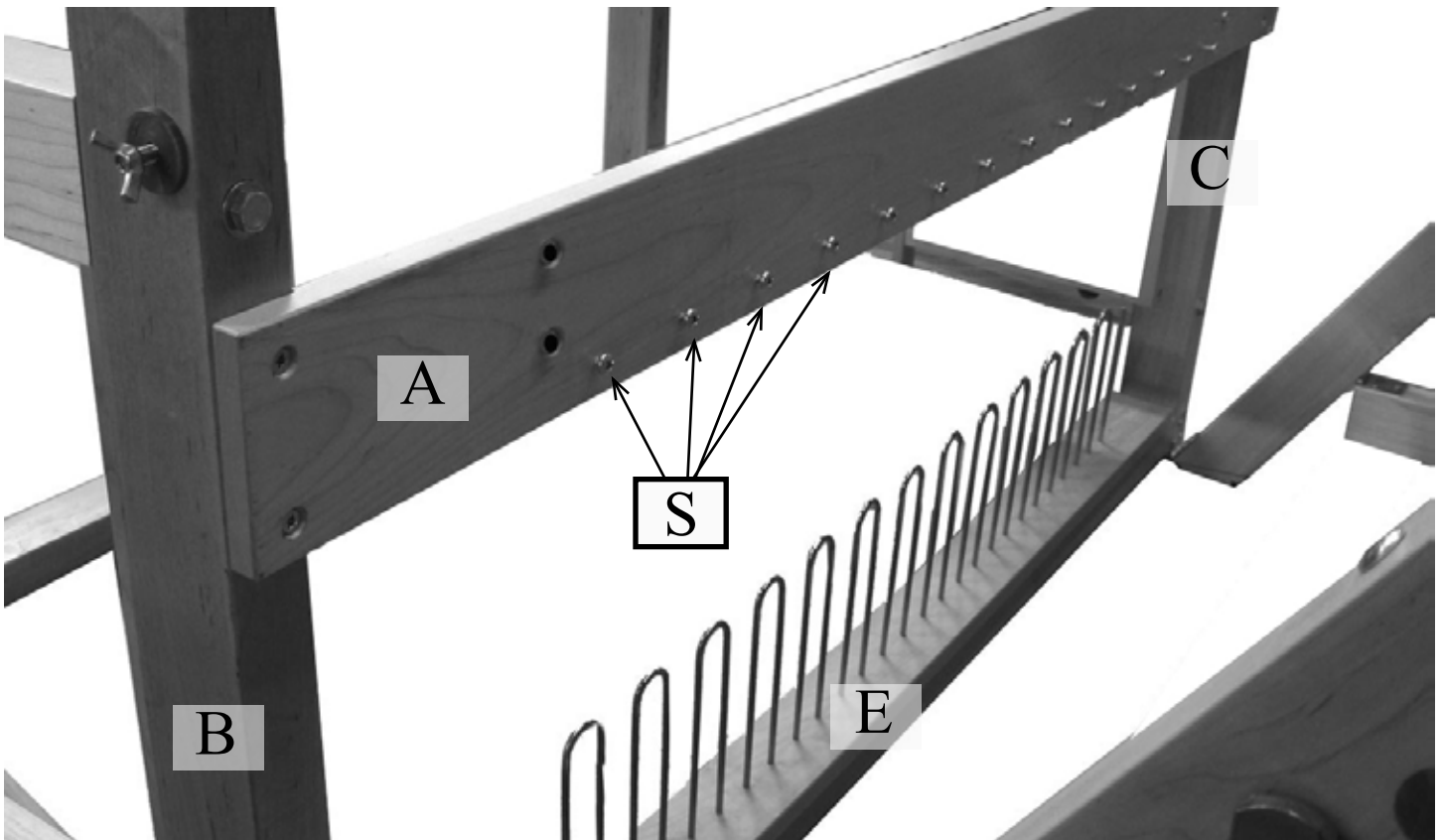

Using four 1 1/2" (40mm) flat-headed screws No. 12, affix the middle cross-member (A) to the rear of the middle posts B and C.

The screws (S) are facing the back of the loom and are in the lower part of the board.

With 2 rounded head screws no 8, 1 1/2", affix the treadle separator (E) to the middle cross member of the loom. make sure to screw it to the pre-drill holes and the middle cross-member.

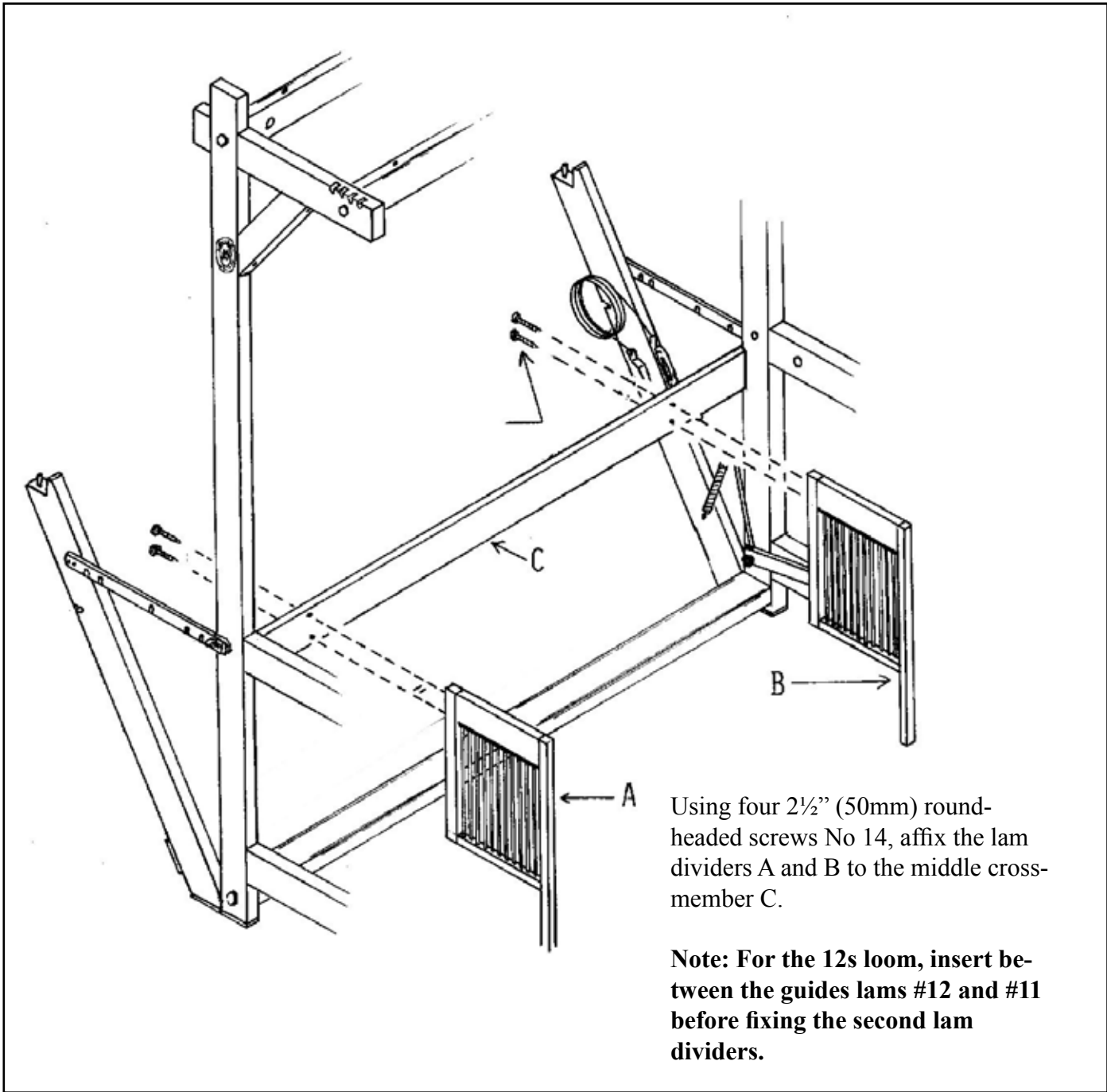

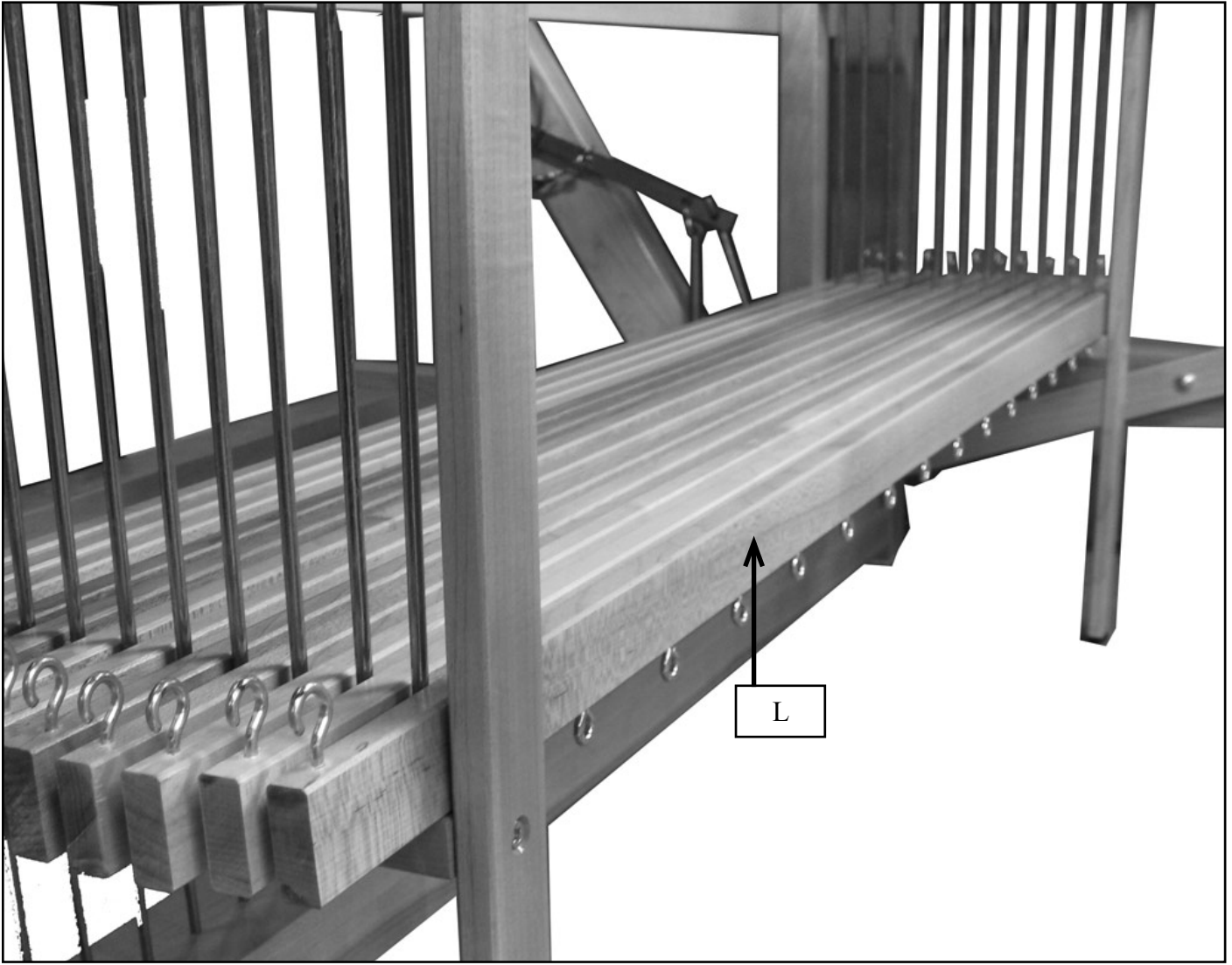

Install lams (L) between the lam dividers (A) and (B), starting at the front.

NOTE: The upper side of the lam has one eyescrew on both ends.

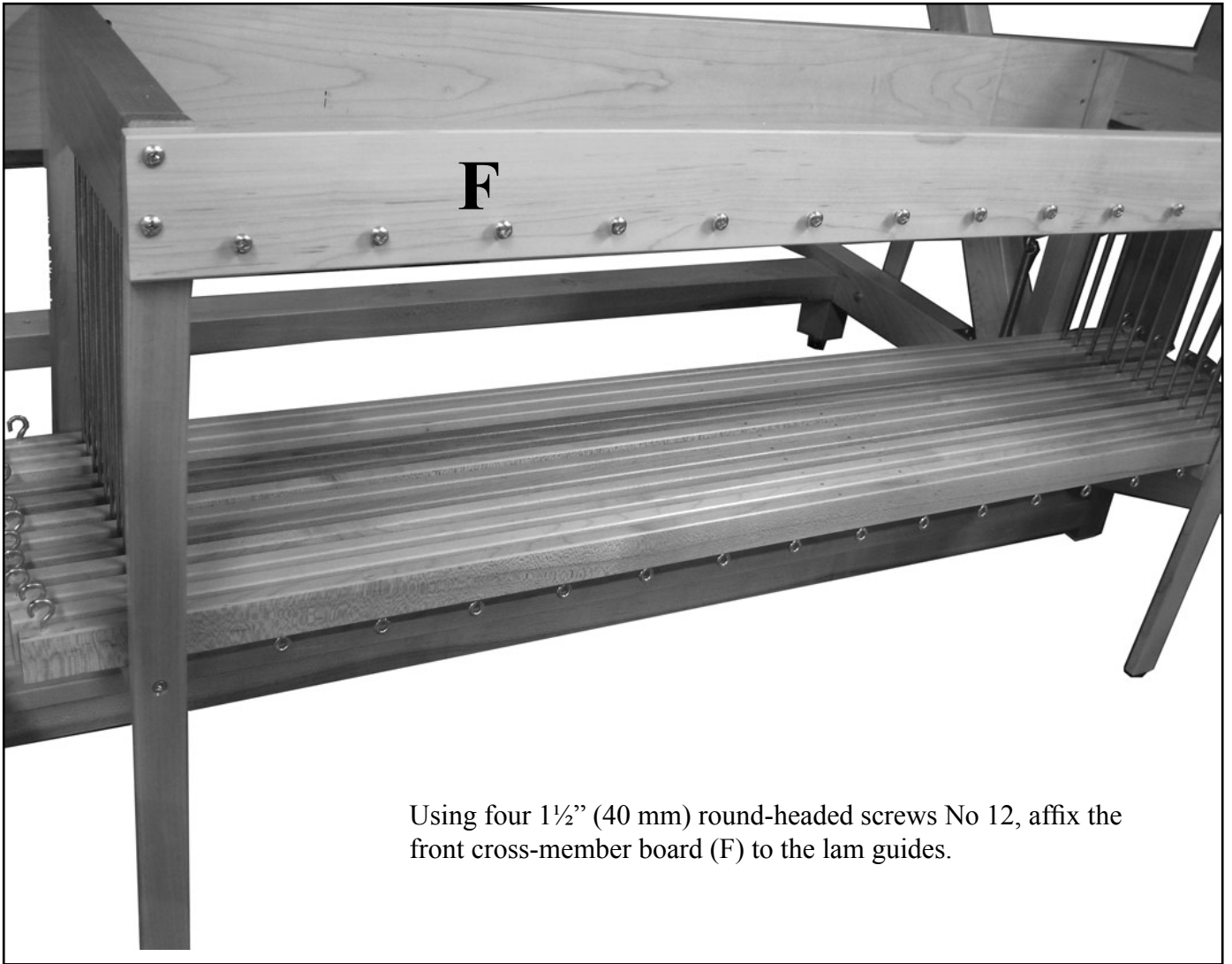

Using four 1½” (40 mm) round-headed screws No 12, affix the front cross-member board (F) to the lam guides.

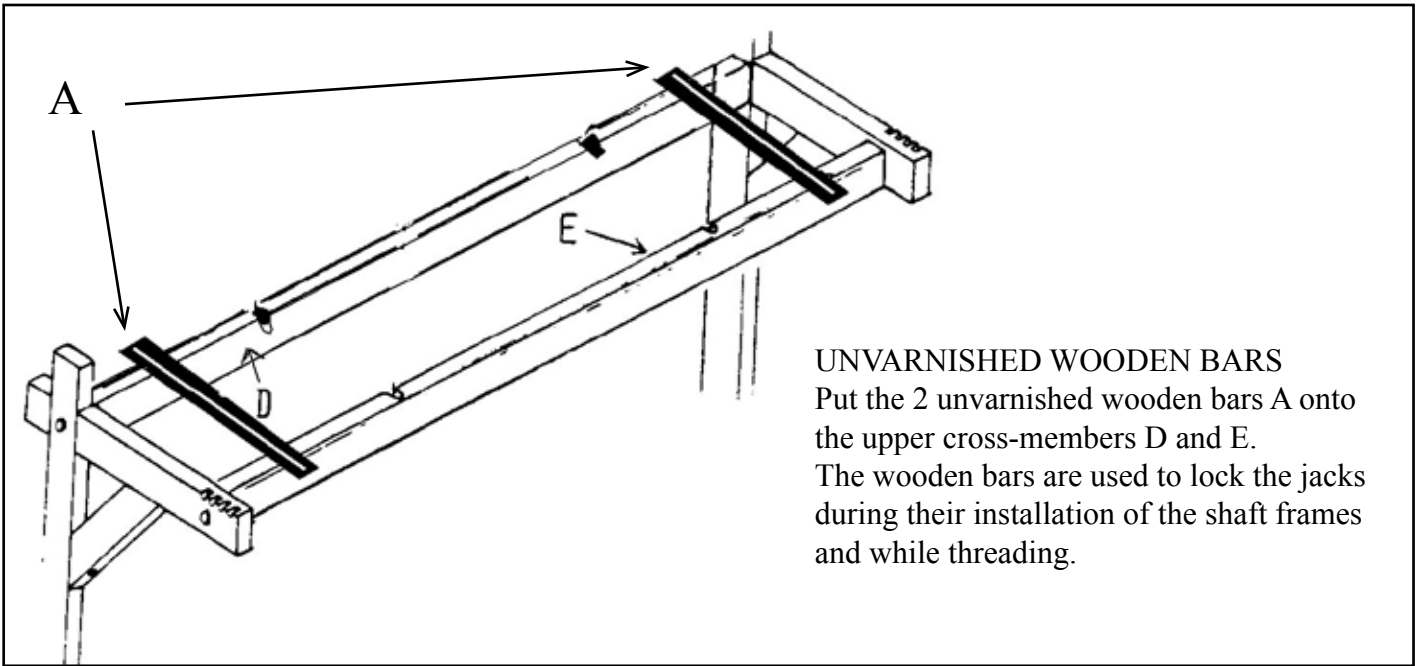

UNVARNISHED WOODEN BARS

Put the 2 unvarnished wooden bars A onto the upper cross-members D and E. The wooden bars are used to lock the jacks during their installation of the shaft frames and while threading.

After removing the saran wrap over the jack assembly, place them to the right side of the upper cross-member inserting the ends of the lower metal jack rods into the notches of the cross-members.

Unfold the jack set and insert the ends of the left metal jack rods into the left notches of the cross-member.



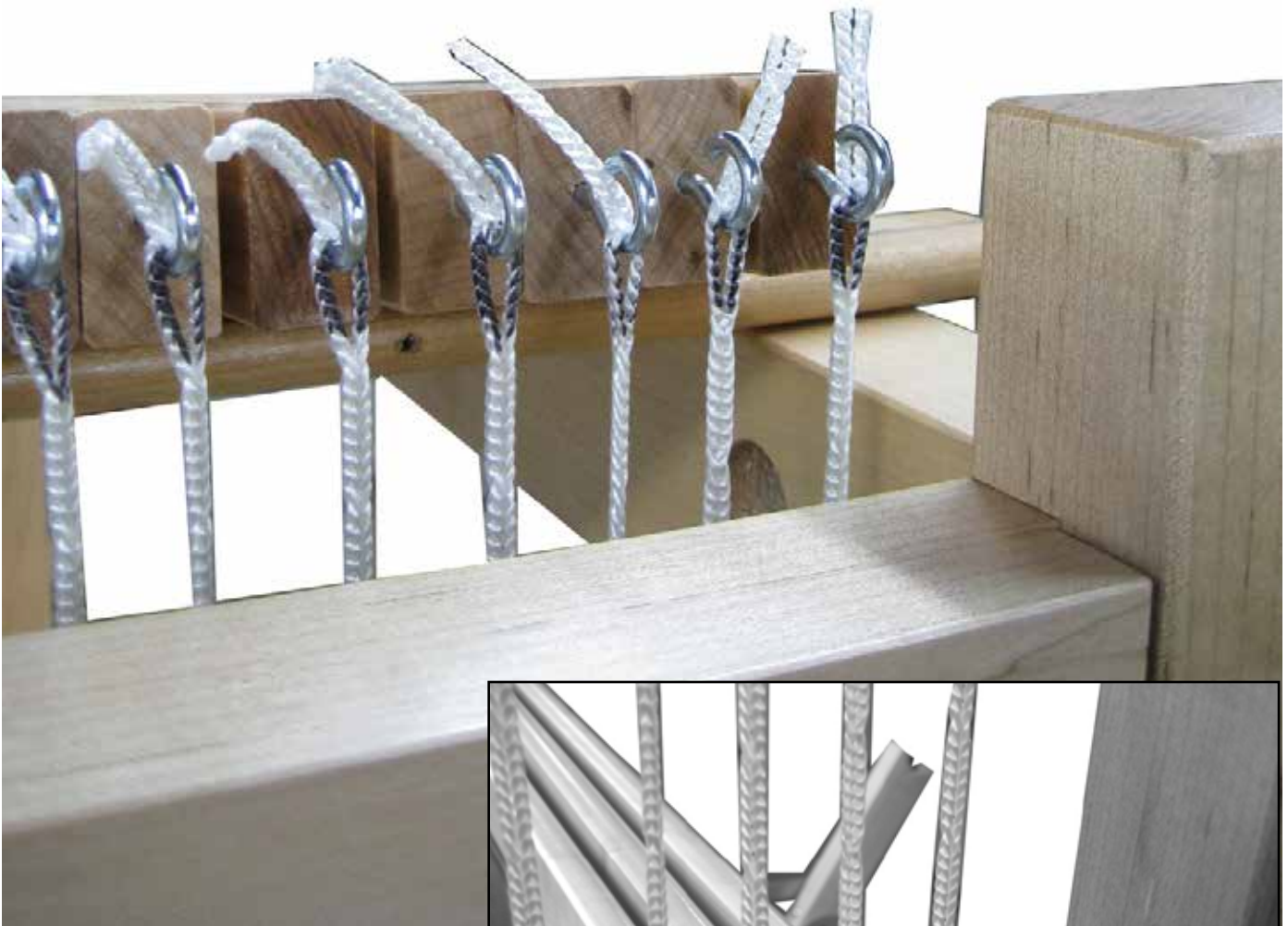

SHAFT FRAME INSTALLATION

The following operation must be done on one shaft frame at a time.

NOTE: Always place the Leclerc Logo of the shaft frame facing the front (top) of the loom.

Connect shaft frame to Jacks, using the loop cords 24".
Insert at the black mark on both ends.

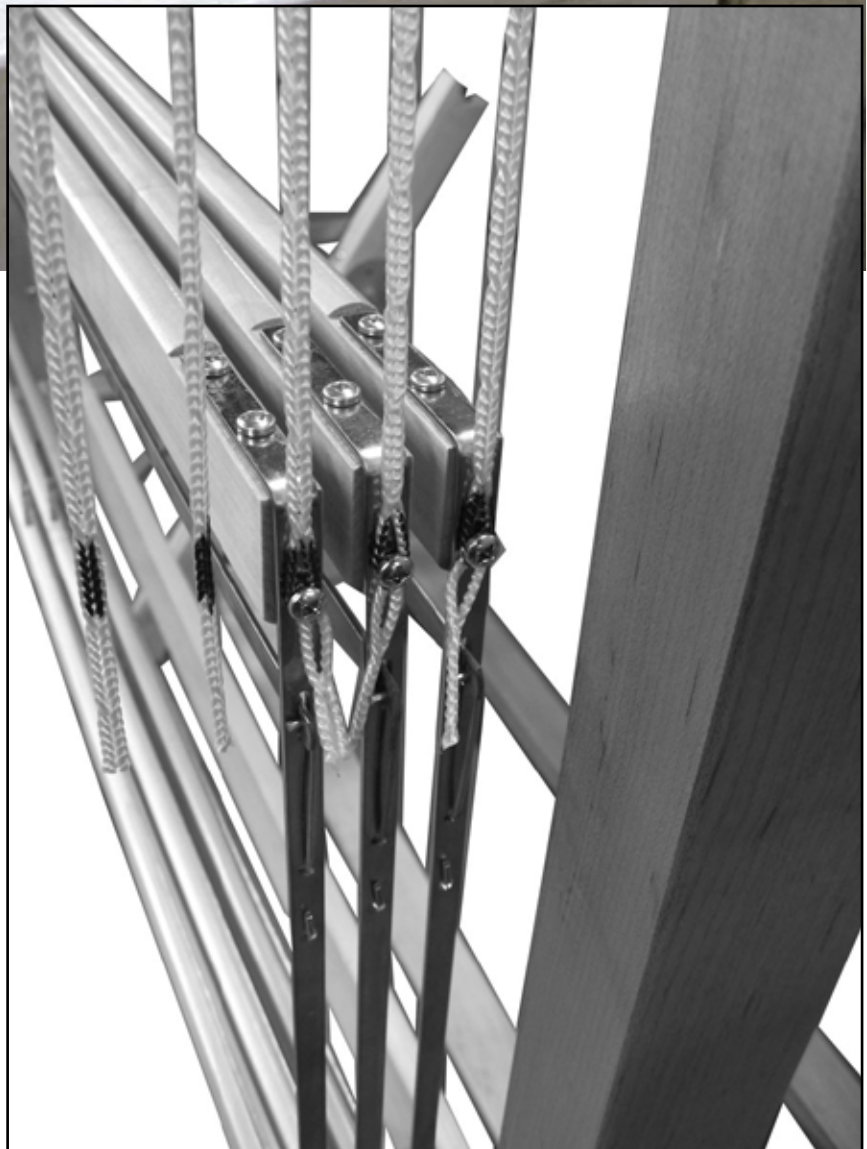

See also the next page....

Install the heddles in the shaft frames. (see “WARP AND WEAVE” on page 10)

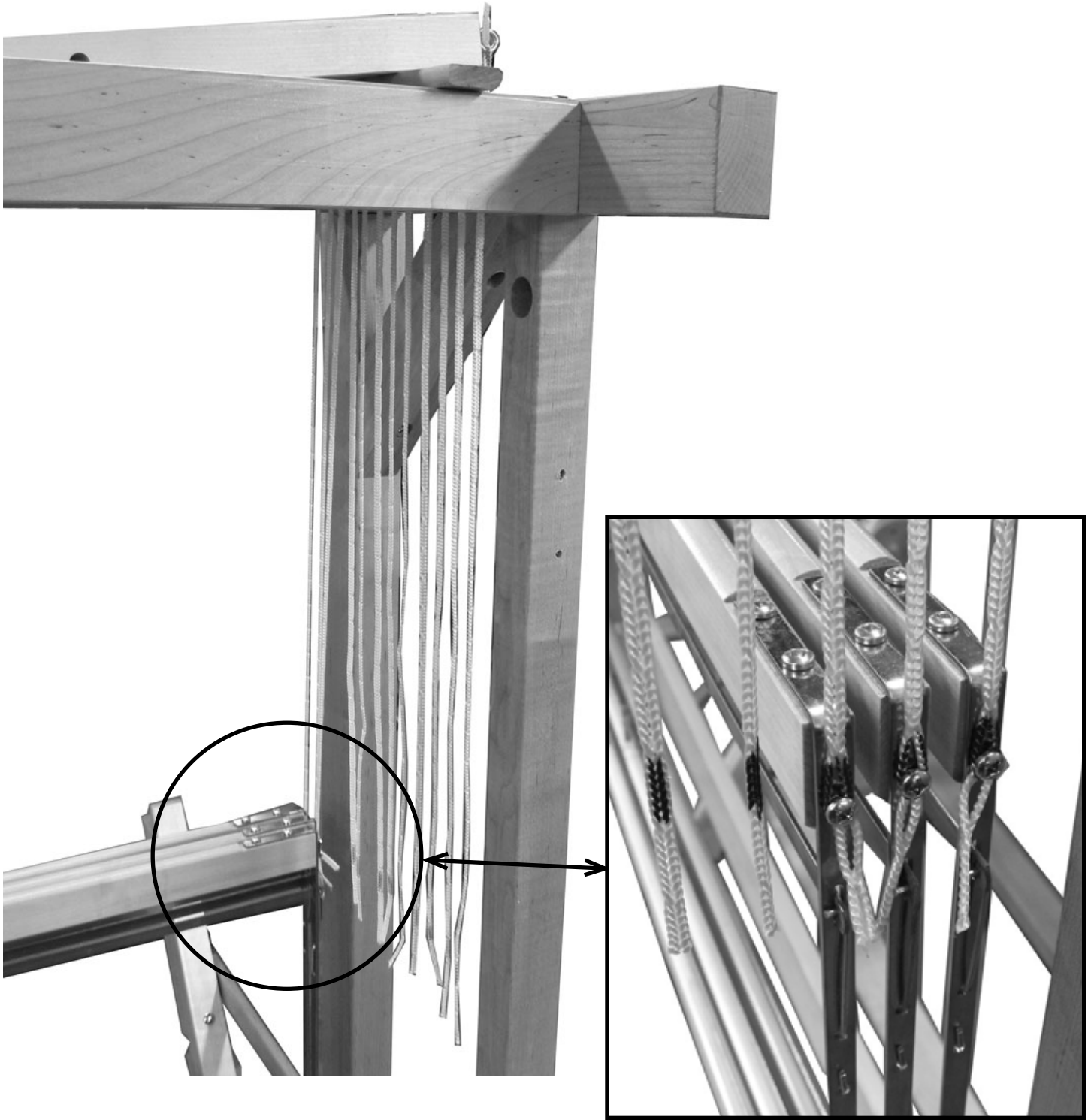



Affix the pulleys box (A) to the uprights using 8 rounded head screws #12 1/2"
Do not remove the saran wrap until it is in the loom.
The front side is indicated to the front board.
All the loop cord ends have to be in the top side.

IMPORTANT:

All loops cords of this box have been threads and marked before shipping.
They have been also lock in place with 3 metal rods.

Remove the saran wrap.

Remove the protecting carboard pieces but **DO NOT REMOVE THE METAL RODS YET.**

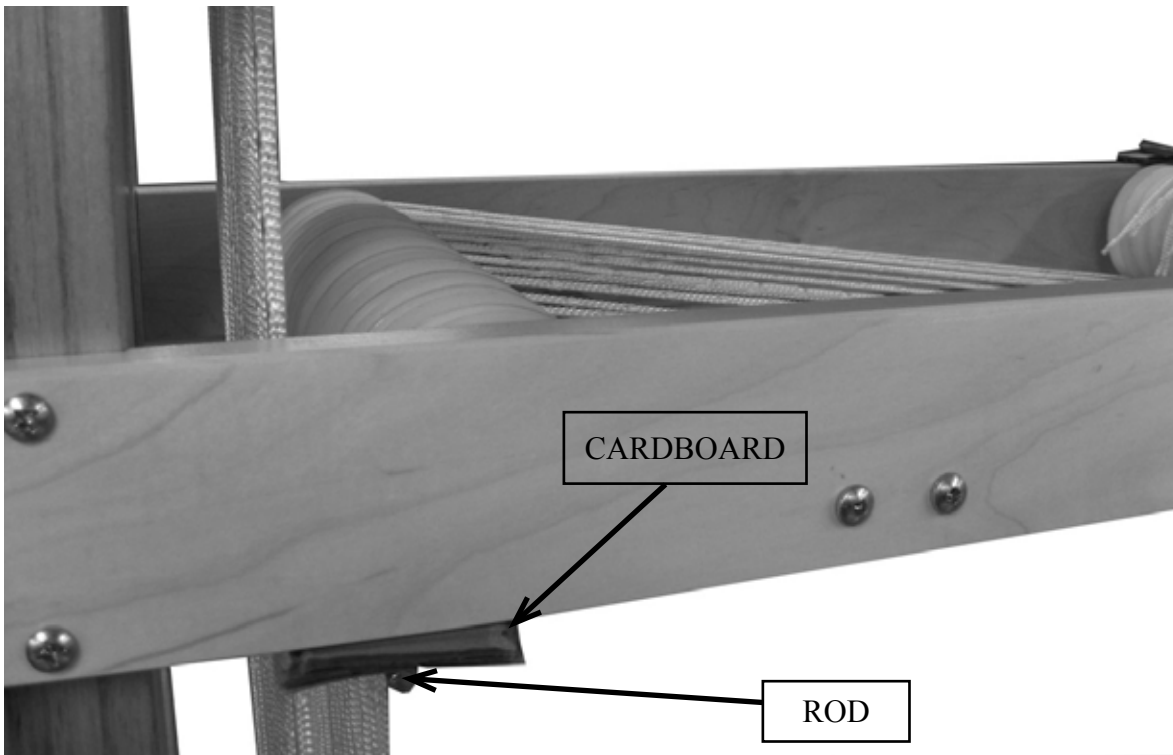
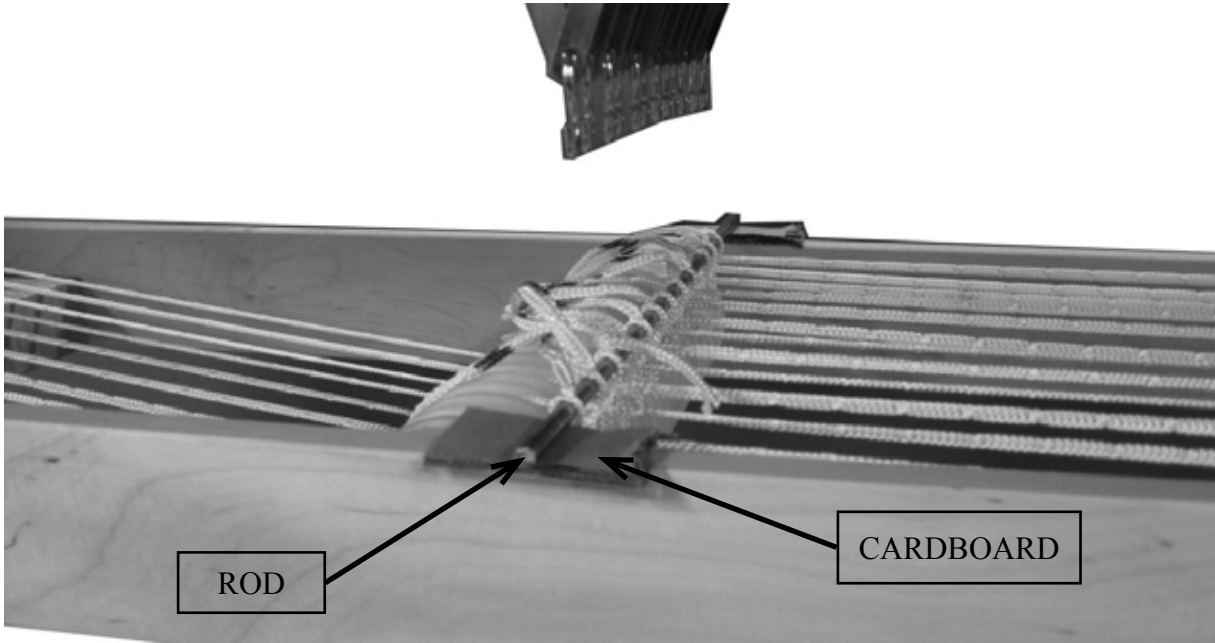

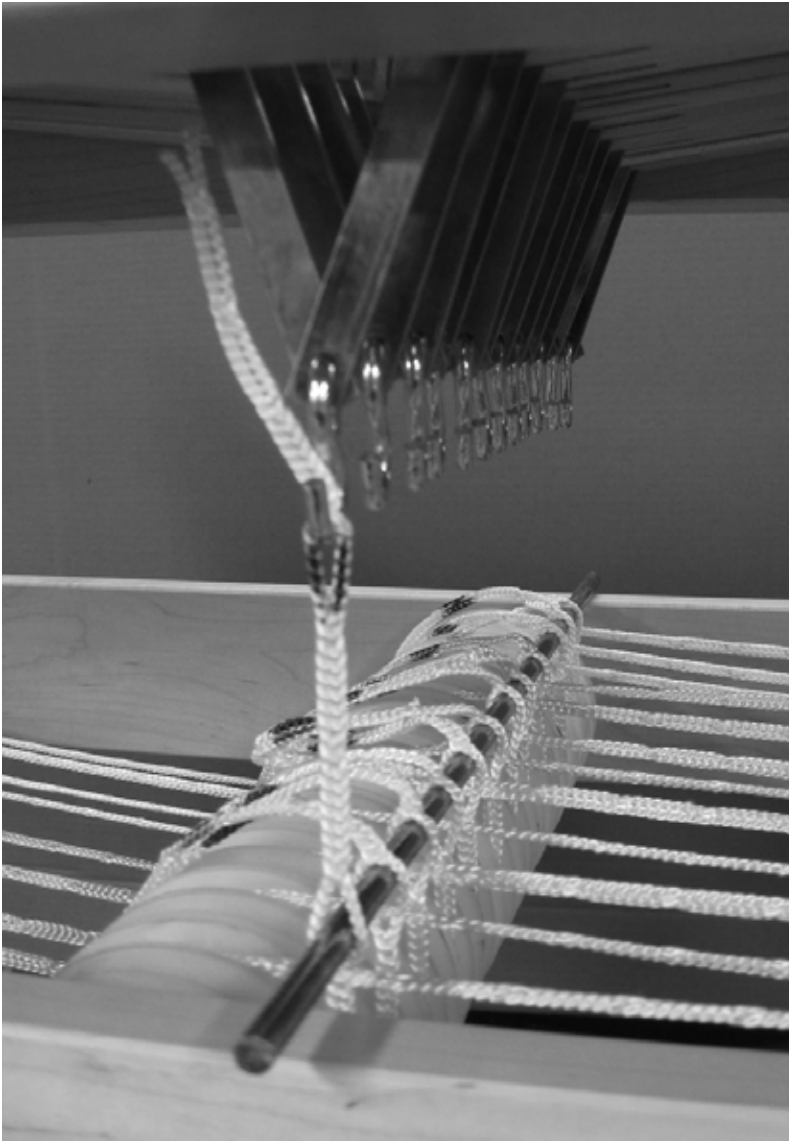

Attach each middle cords to the upper S hooks.
#1 cord to #1 S hook
#2 cord to #2 S hook
ect.

DO NOT REMOVE THE ROD.

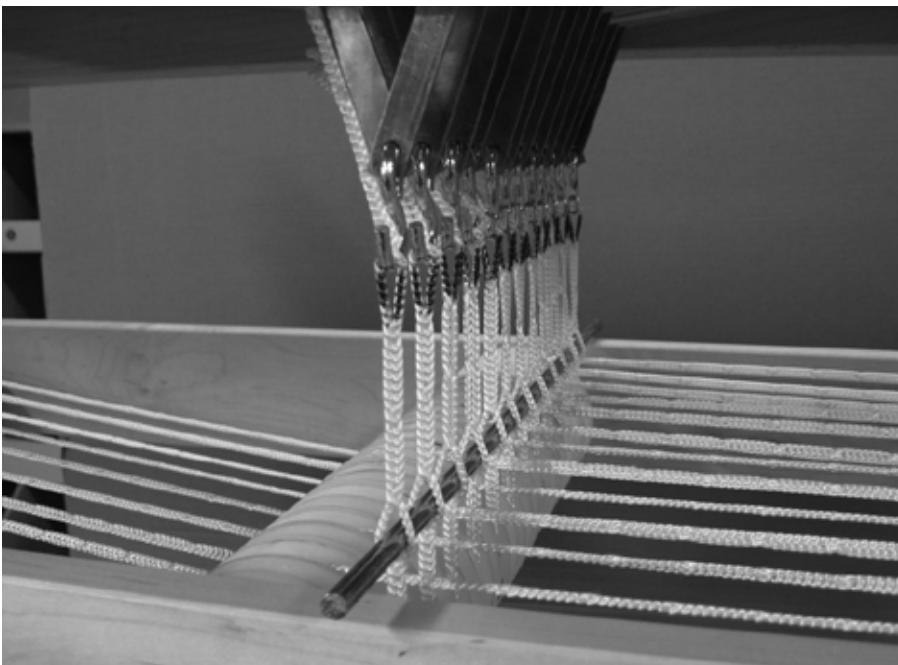

Thread and attach at the black mark each side loop cords from the pulley to the lam passing each time at the back of each shaft frame.

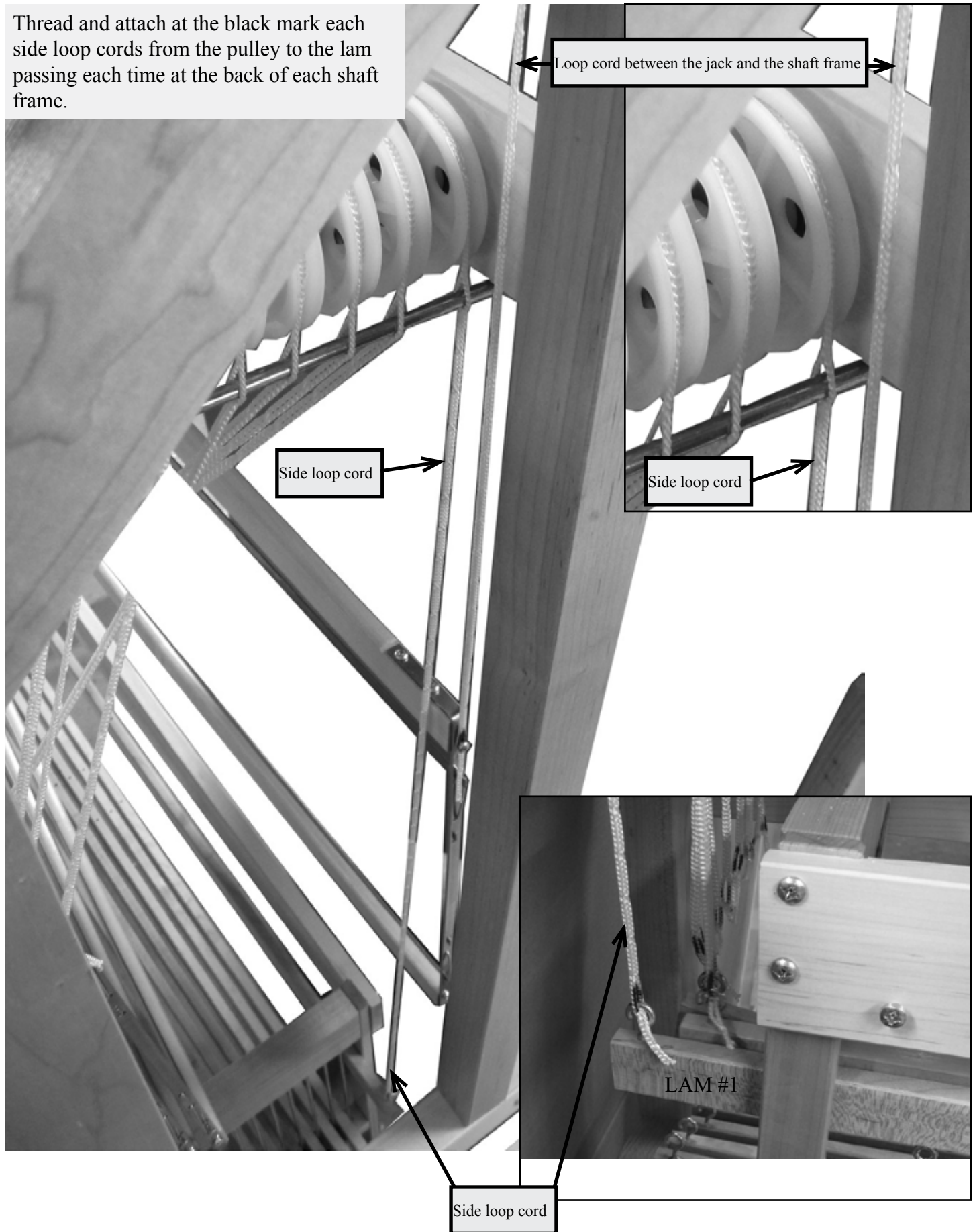



Make sure that all loop cords are in the groove of each pulley.

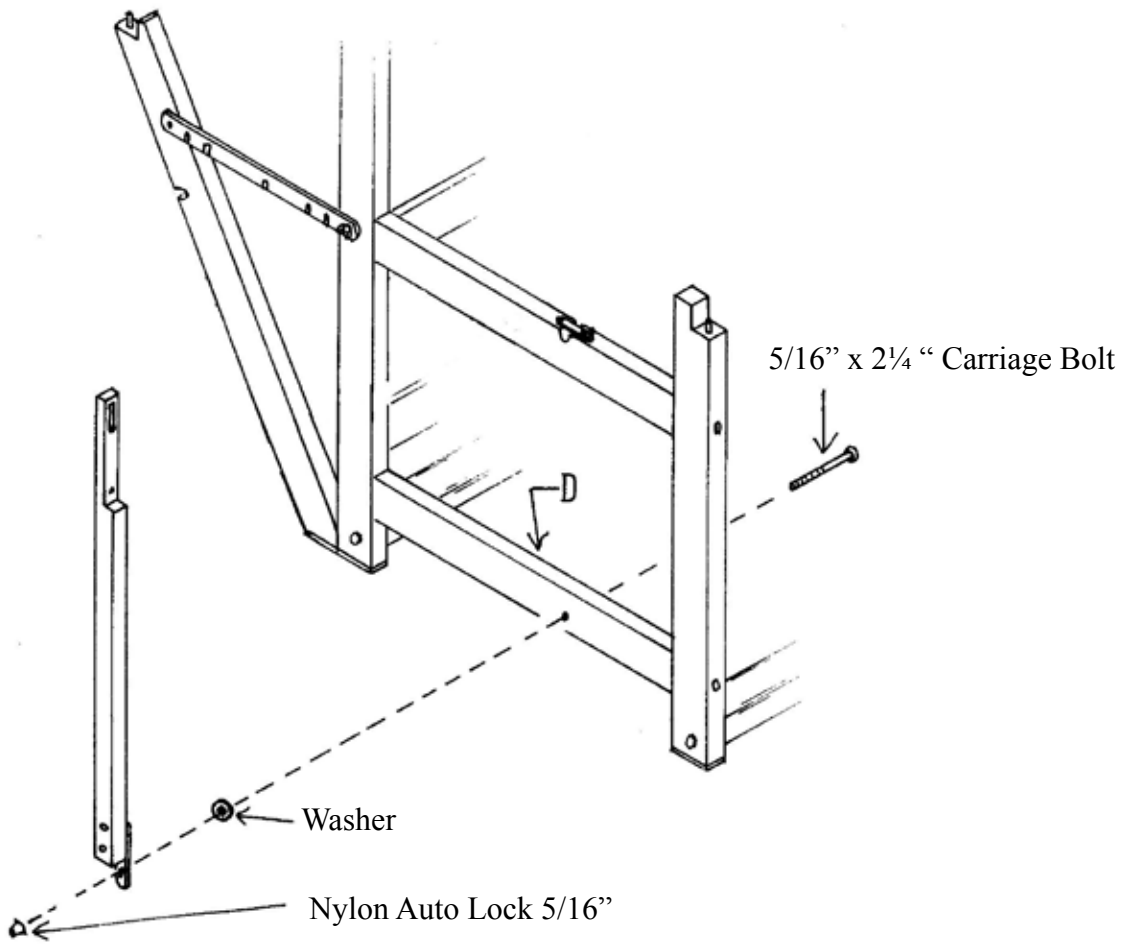

Affix batten swords C to lower lateral cross-member D, using two 5/16" x 2 1/4" carriage bolts, four steel washers, and two 5/16" wing nuts. Place a steel washer between the sword and the cross-member.

NOTE: Hammer the carriage bolt inside the hole so it will lock while you will screw in the auto lock nuts.

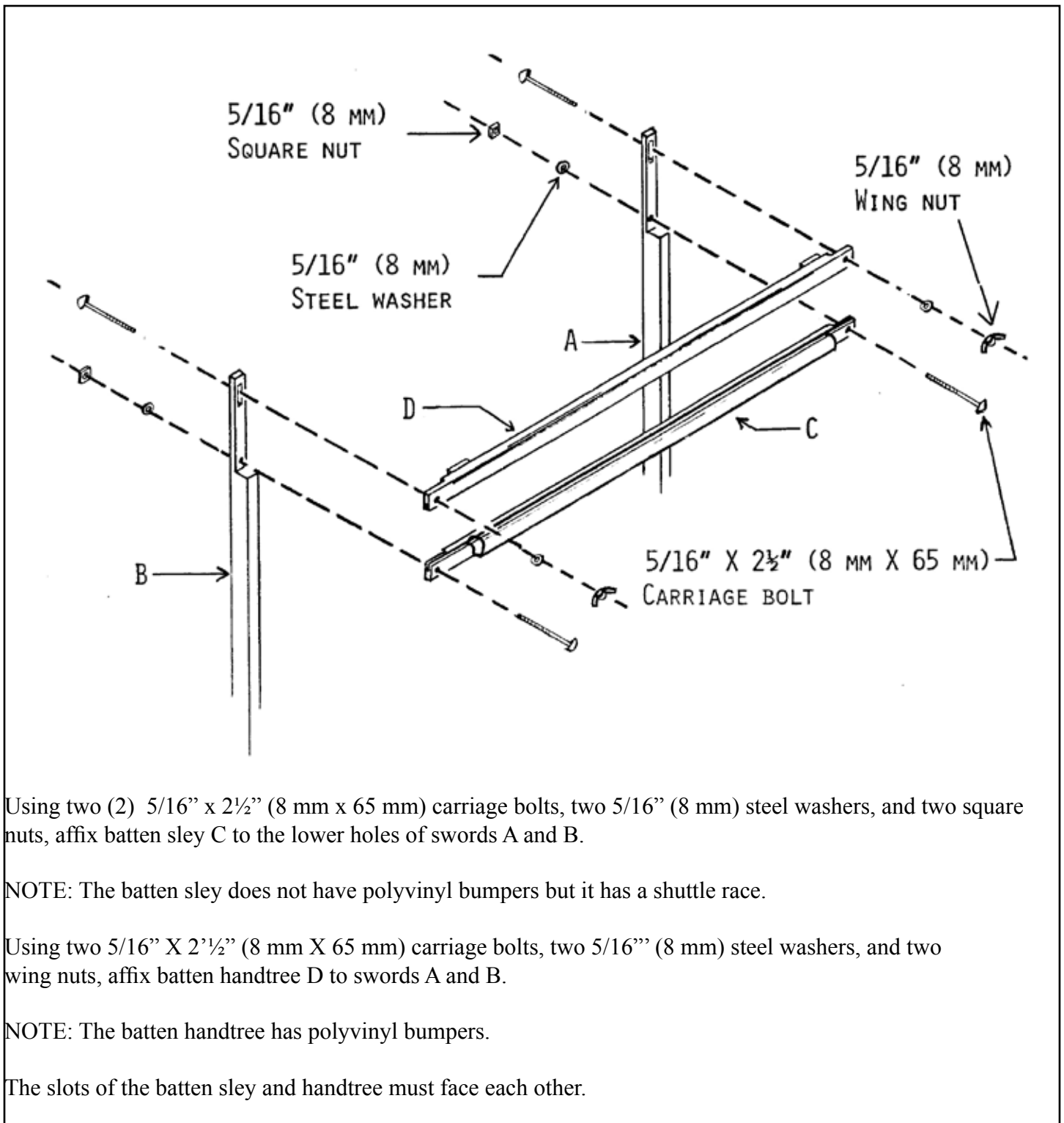

Using two (2) 5/16" x 2½" (8 mm x 65 mm) carriage bolts, two 5/16" (8 mm) steel washers, and two square nuts, affix batten sley C to the lower holes of swords A and B.

NOTE: The batten sley does not have polyvinyl bumpers but it has a shuttle race.

Using two 5/16" X 2½" (8 mm X 65 mm) carriage bolts, two 5/16" (8 mm) steel washers, and two wing nuts, affix batten handtree D to swords A and B.

NOTE: The batten handtree has polyvinyl bumpers.

The slots of the batten sley and handtree must face each other.

TREADLE SET ASSEMBLY 8s

Assemble the treadle set (in or out of the loom).

- 1 treadle rod $1\frac{3}{4}$ " with one push nut already on one side.
- 10 treadles
- 8 wood spacers $1\frac{1}{2}$ "
- 3 treadle blocks
- 4 x $9/16$ " washers
- 1 push nut to be installed after the set is on the loom.

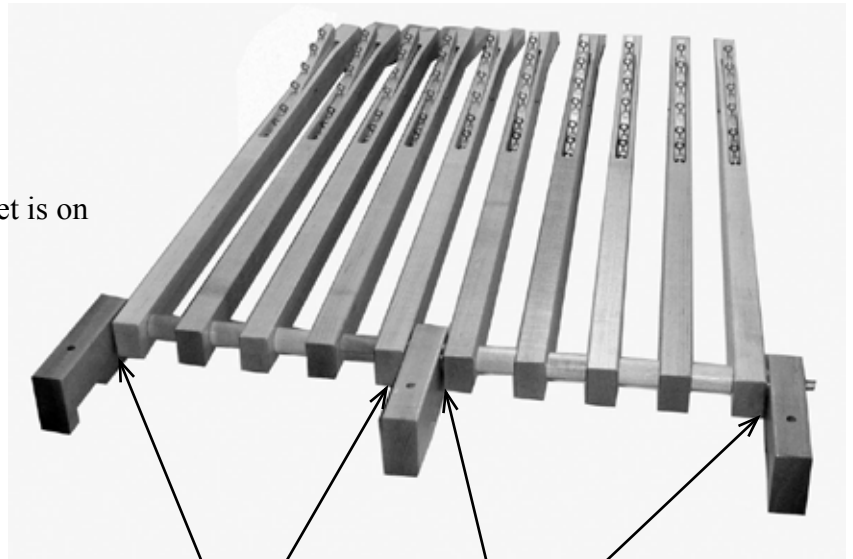

4 washers $9/16$ " are installed between treadle and treadle block.

TREADLE SET ASSEMBLY 12 Loom

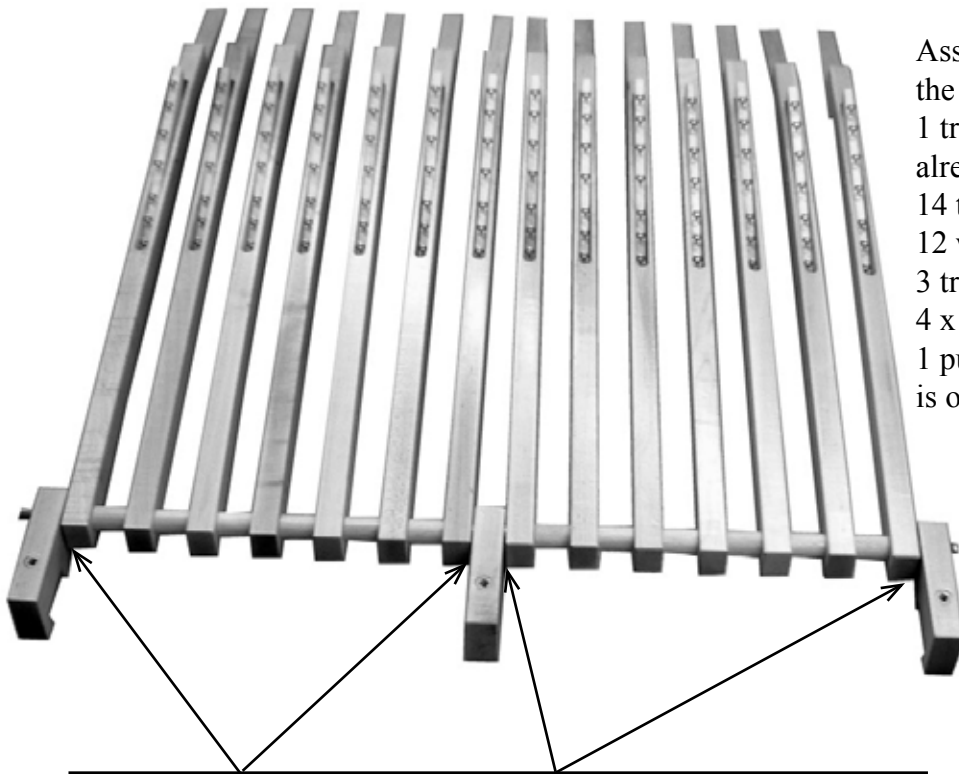

Assemble the treadle set (in or out of the loom).

1 treadle rod $28\frac{3}{4}$ " with one push nut already on one side.

14 treadles

12 wood spacers $1\frac{1}{2}$ "

3 treadle blocks

4 x $\frac{9}{16}$ " washers

1 push nut to be installed after the set is on the loom.

4 washers $\frac{9}{16}$ " are installed between treadle and treadle block.

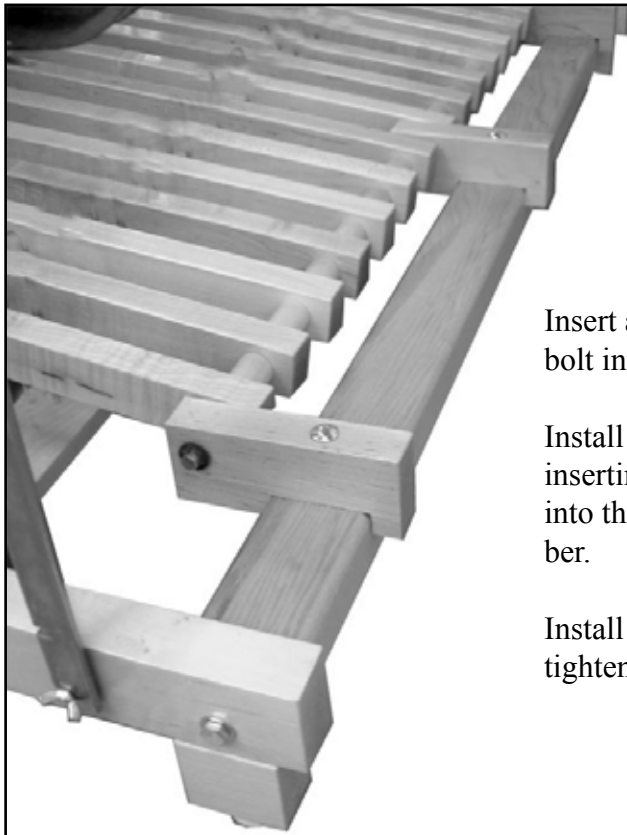

Insert a $\frac{5}{16}$ " x $4\frac{1}{2}$ " (8mm x 95mm) carriage bolt into each of the three treadle set supports.

Install treadle set on the cross-member by inserting the three $\frac{5}{16}$ " x $4\frac{1}{2}$ " carriage bolts into the appropriate holes of the cross-member.

Install a $\frac{5}{16}$ " (8mm) washer underneath, and tighten with the square nuts.



You can install now or just before weaving the treadles springs.
- The clip go to the eyescrew of the treadle.
- The loop cord black mark to the top screw.
After the installation, the treadles will be all at the same height.

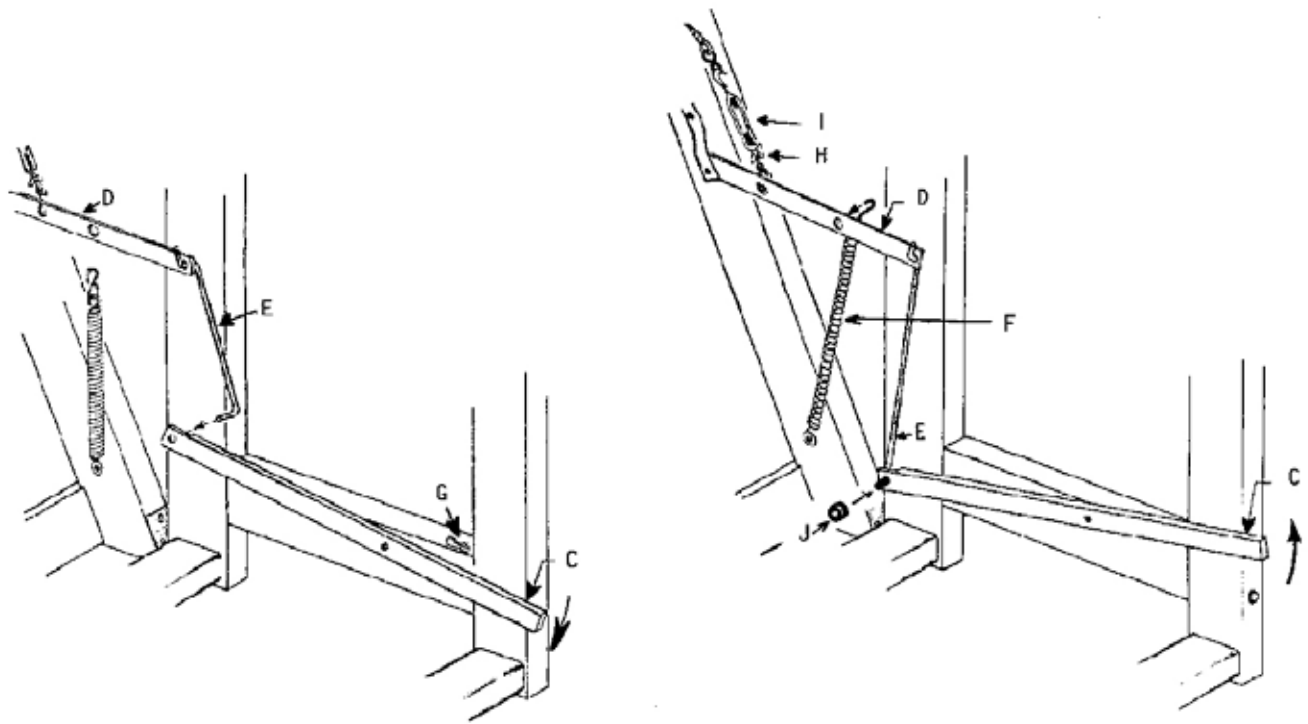

Using metal rod E, join treadle C to lever D. First insert the double-cornered end of the metal rod into lever D; then insert the other end of the metal rod into treadle C while the treadle is depressed.

Raise (back part) treadle C as high as possible then hook spring F to lever D.

BRAKE ADJUSTMENT:

Release the brake by depressing treadle C and locking it down with the catch G. The warp beam should turn freely but the circular brake wire should not be too slack. If the tension is too great, unscrew the wing nut H slightly and then loosen the turnbuckle I. If the tension is too slack, tighten the turnbuckle I slightly and then the wing nut H.

Insert the black rubber ring J to the lower end of the rod E, to prevent the rod from slipping out.

BEAMING

Release the brake by depressing the brake treadle (C) and locking it down with catch (G).

WEAVING

To advance the warp, depress brake treadle (C) and turn cloth beam (H) at the same time. Then, release brake treadle (C) (engaging the brake) and advance the cloth beam until the desired tension is achieved.

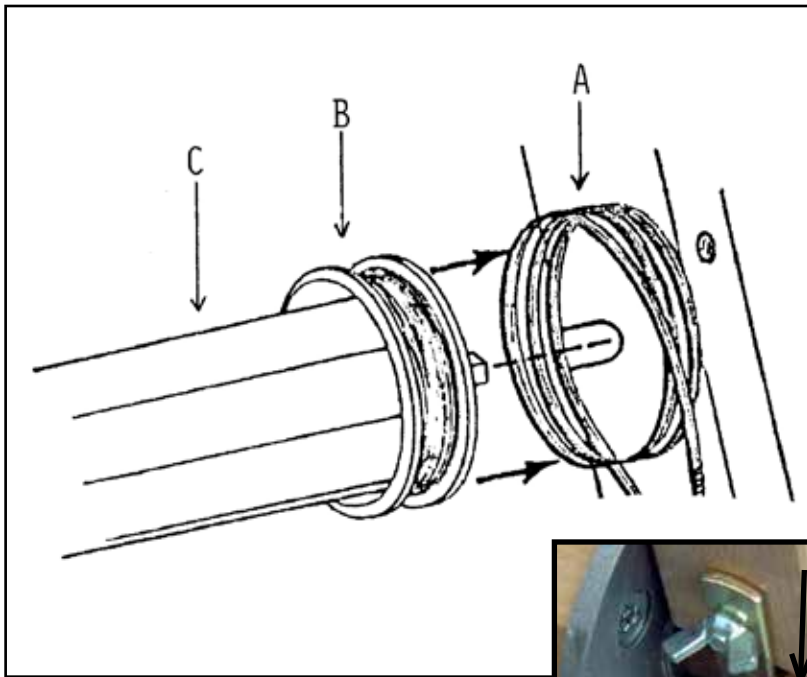

WARP BEAM INSTALLATION

Hold the circular wire brake shoe A slightly to the rear of the loom, **but do not unroll it.**

Insert the brake drum B into the wire brake shoe A. Then, install the ends of the warp beam C into the grooves of the back posts.

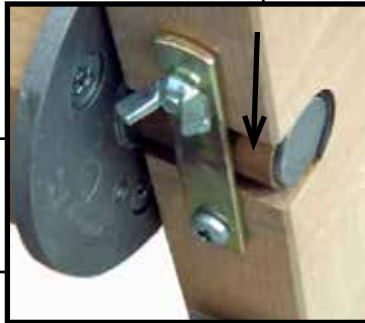

In order to improve the rotation of the warp beam, special bushings are supplied. Make sure to leave them in place when installing the warp beam on the loom.

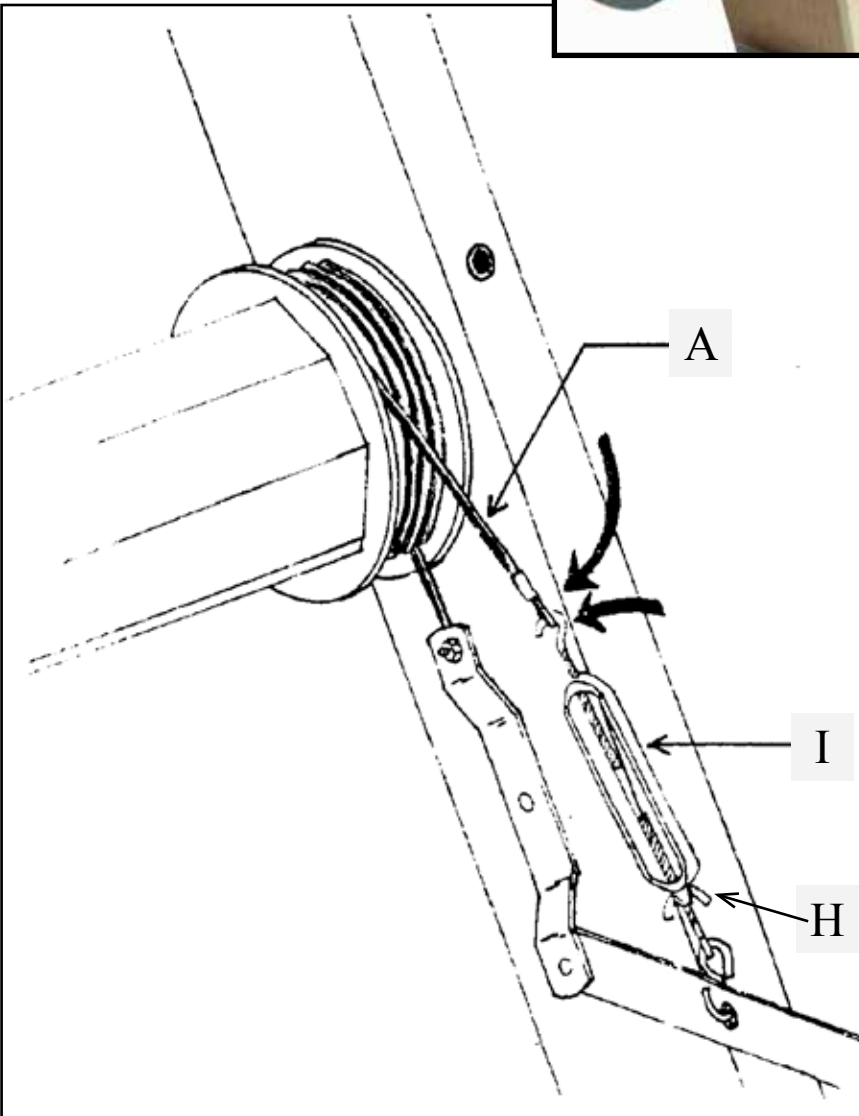

Hook turnbuckle I to flat wire circle A.

BRAKE ADJUSTMENT:

Release the brake by depressing the brake treadle and locking it down with the catch G.

The warp beam should turn freely but the brake circle should not be too slack. If the tension is too great, unscrew the wing nut H slightly and then loosen the turnbuckle I. If the tension is too slack or the beam is turning counterclockwise (while standing on the brake side of the loom), tighten the turnbuckle I slightly and then the wing nut H.

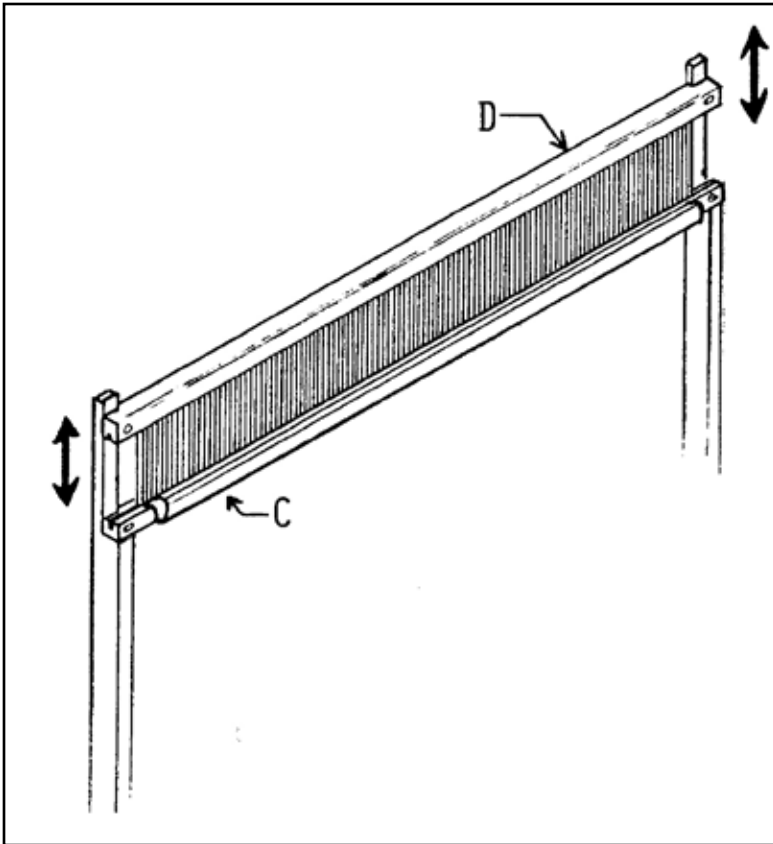

Place the reed between batten sley C and handtree D. When the wing nuts are loose, the batten handtree can slide vertically in the sword slots. The reed must then be secured between the batten sley and handtree by tightening the wing nuts. If the batten does not touch the two bumpers equally, loosen the bolts of the batten sley and handtree and exert pressure on the batten centering it in its proper place. Tighten the bolts again.

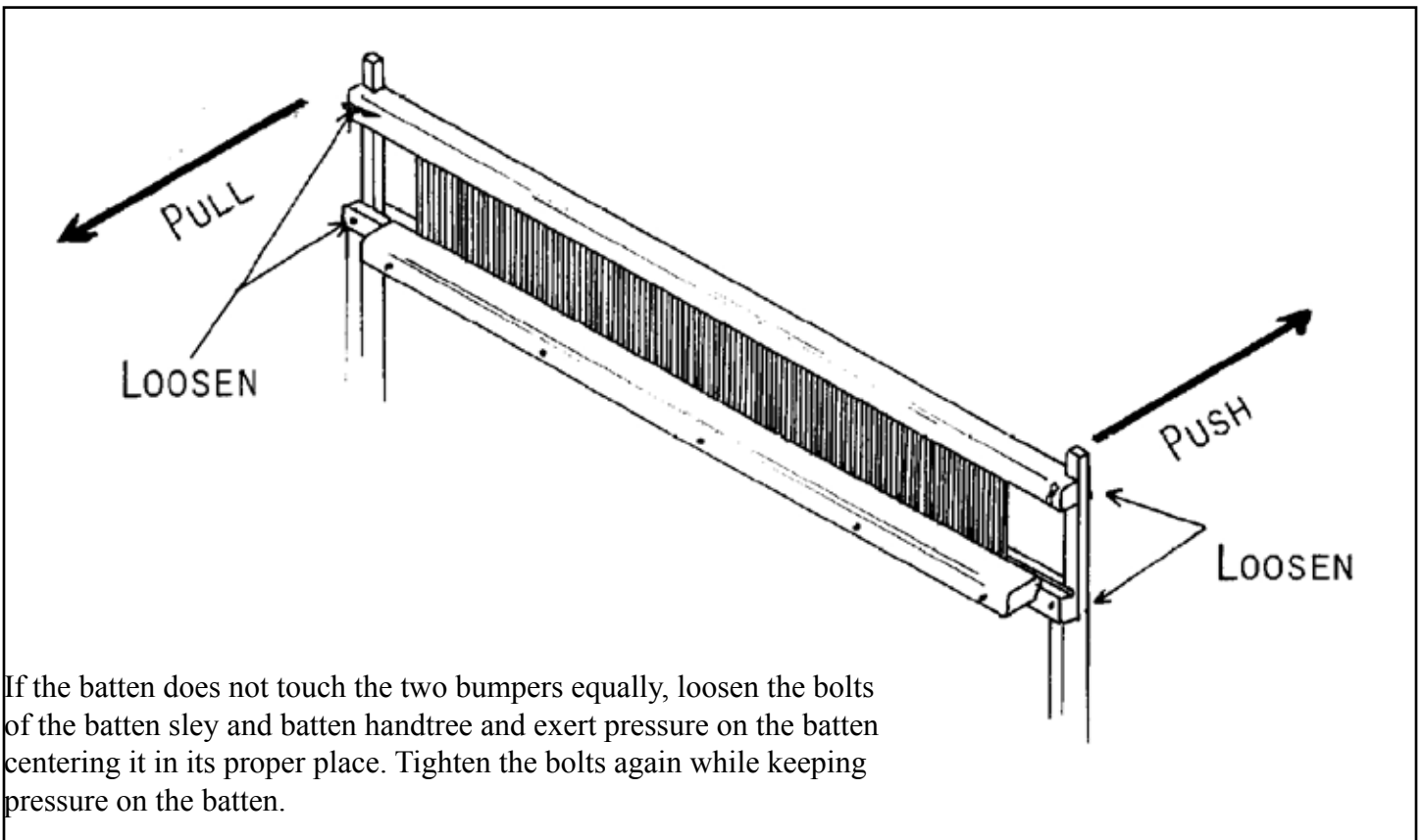

If the batten does not touch the two bumpers equally, loosen the bolts of the batten sley and batten handtree and exert pressure on the batten centering it in its proper place. Tighten the bolts again while keeping pressure on the batten.

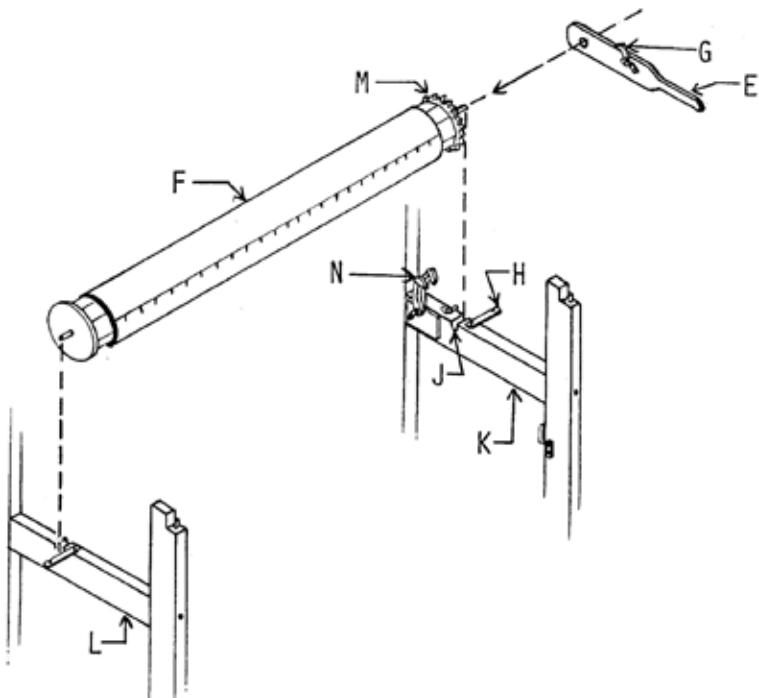

Install take-up motion handle E on the axle end of cloth beam F (on the same side as the ratchet gear). Ratchet pawl G of the take-up motion handle must be lifted up.

Open beam latches H and place the beam ends in the slots J of the upper side cross- members K and L.

Note: Ratchet gear M must be on the right-hand side and ratchet pawls N must be lifted up.

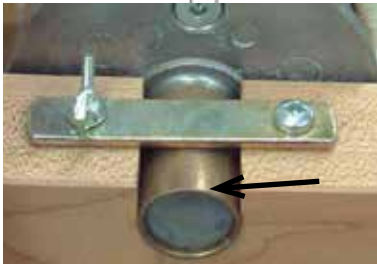

In order to improve the rotation of the cloth beam, special bushings are supplied. Make sure to leave them in place when installing the cloth beam on the loom.

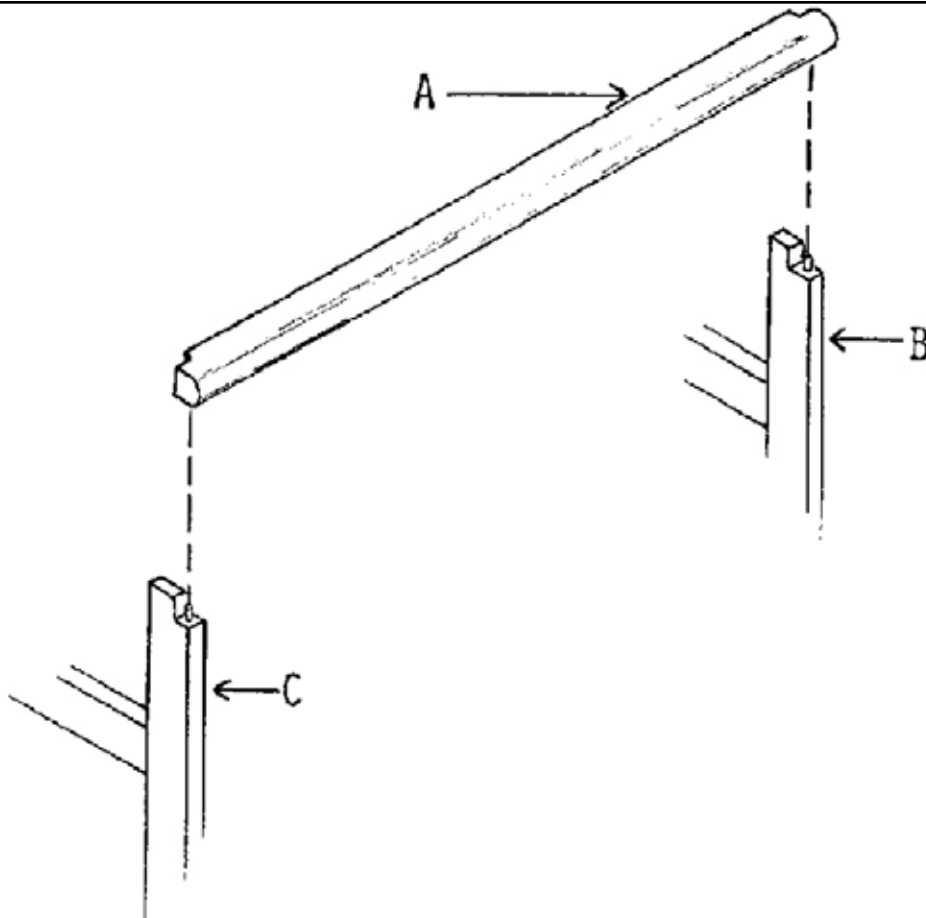

Affix one of the breast beams A on the top of the front posts B and C.

Affix the other breast beam on top of the back posts.

NOTE: To avoid splitting the front posts, slightly insert the breast beam onto the metal pin. Be sure that it is in the right position before inserting it completely.

FOLDING LOOM AND BEAMING:

Release the brake by depressing treadle C and by locking it down with catch G. Release the 4 metal hooks and fold the back of the loom.

WEAVING:

To advance the warp, depress brake treadle C and turn cloth beam H at the same time. Then release brake treadle C and advance the cloth beam until the next notch in the ratchet gear is reached.

If this is too much tension, gently depress the brake treadle until the desired tension is obtained.

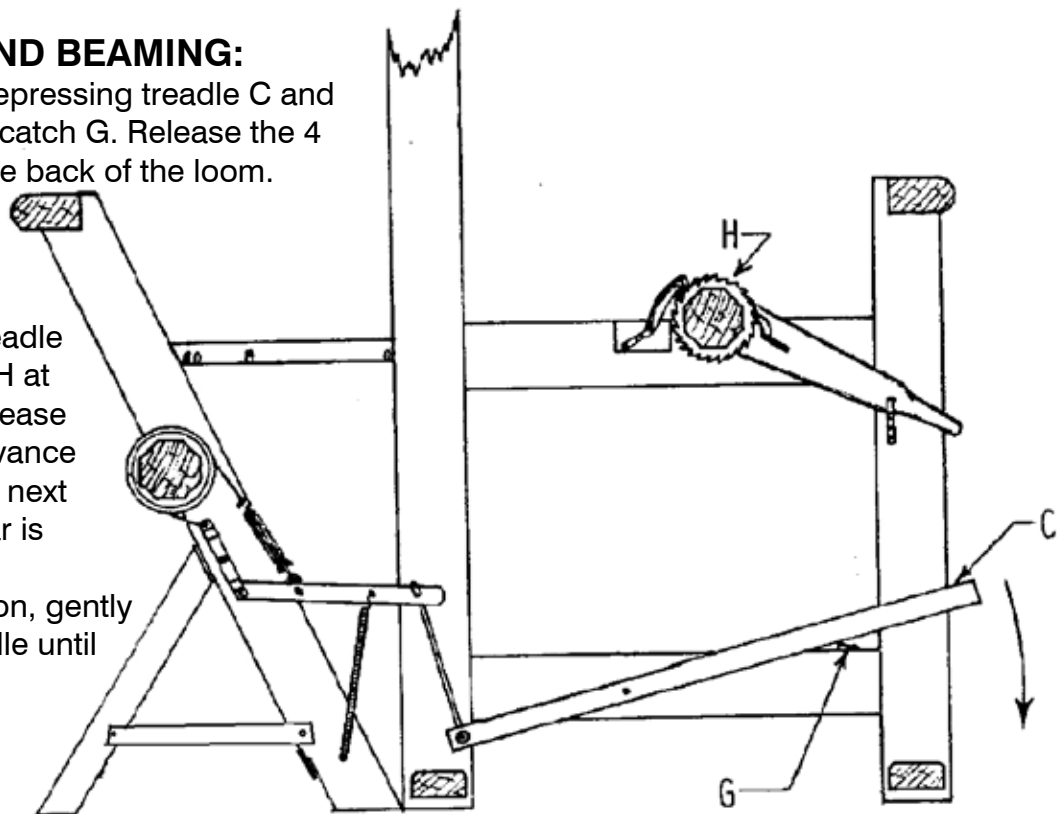

Note while winding a warp with a Leclerc Friction Brake

To maintain proper adjustment and operation of your Friction Brake, it is recommended that the Brake be disengaged while winding the Warp.

On those looms designed with a Treadle or Lever Lock, the Brake should be locked open when winding.

MORE INFORMATION:

See "WARP AND WEAVE"

Install the Warp beam advance control system. This system will eliminate excessive warp yarn advance when releasing the brake system at cloth take-up.

This friction system is adjustable and has to be released when winding the warp on.

Just screw the handle in to increase the friction or unscrew it to release.

Affix it to the back left side of the loom using 2 round head screws no 12 - 1" to the pre-drilled holes.

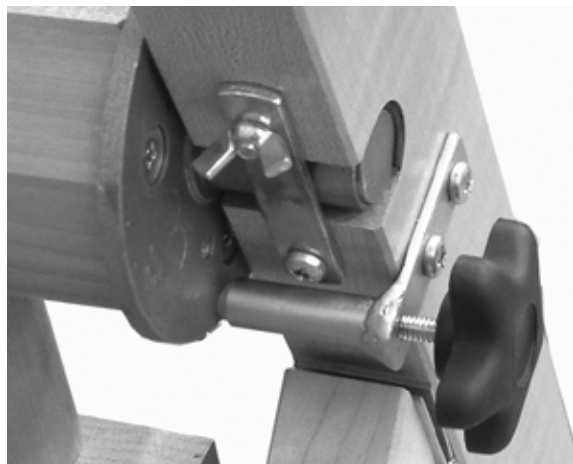

When you are ready to weave, remove the Unvarnished wooden bars (with black stripe) and all 3 metal rods locking the action of the pulleys.

Wood bar

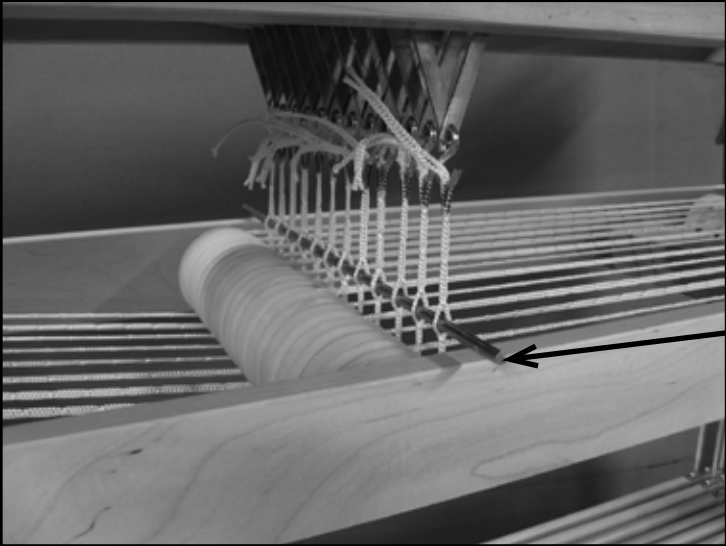
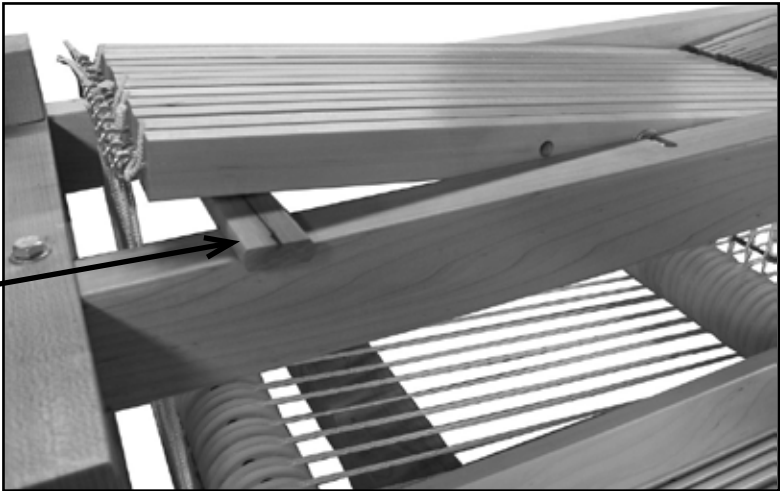

Rods

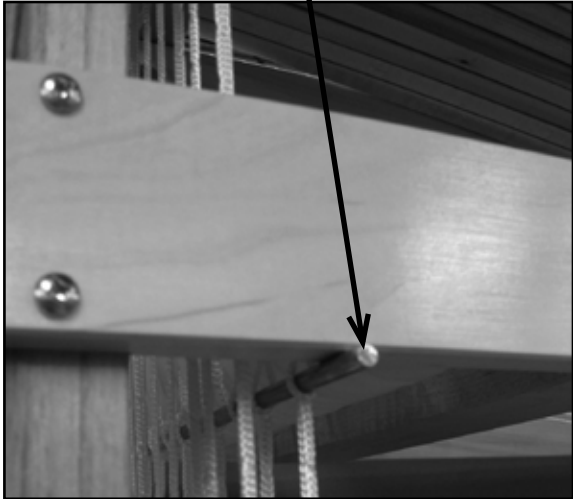



Thread the treadle cords to the eyescrews of the lams as shown in the pictures.

Slide the Treadle Hook through the Screw Eyes and Cord Loops. Before the last Screw Eye, insert the Hook through the Treadle Spring loop cord and secure. In the Treadle rest position(up) there should be no or very little tension on the Spring. However slack on those cords is not desirable. When all treadles are tied up, they should be at the same height.

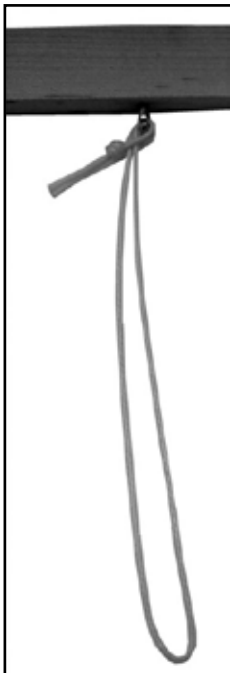

Treadle Cords

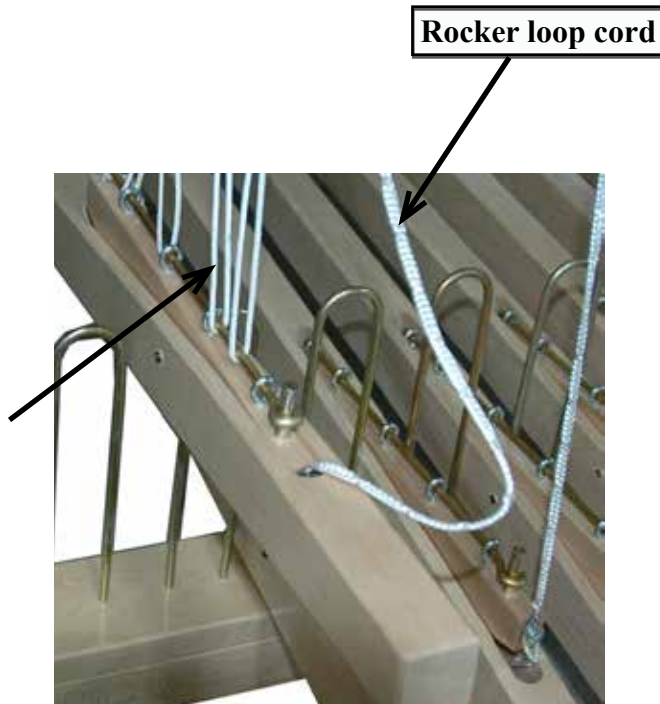



Install the Treadle Rocker Loop Cord on the Anchors(Screw Heads) using the marked points at the Anchor.

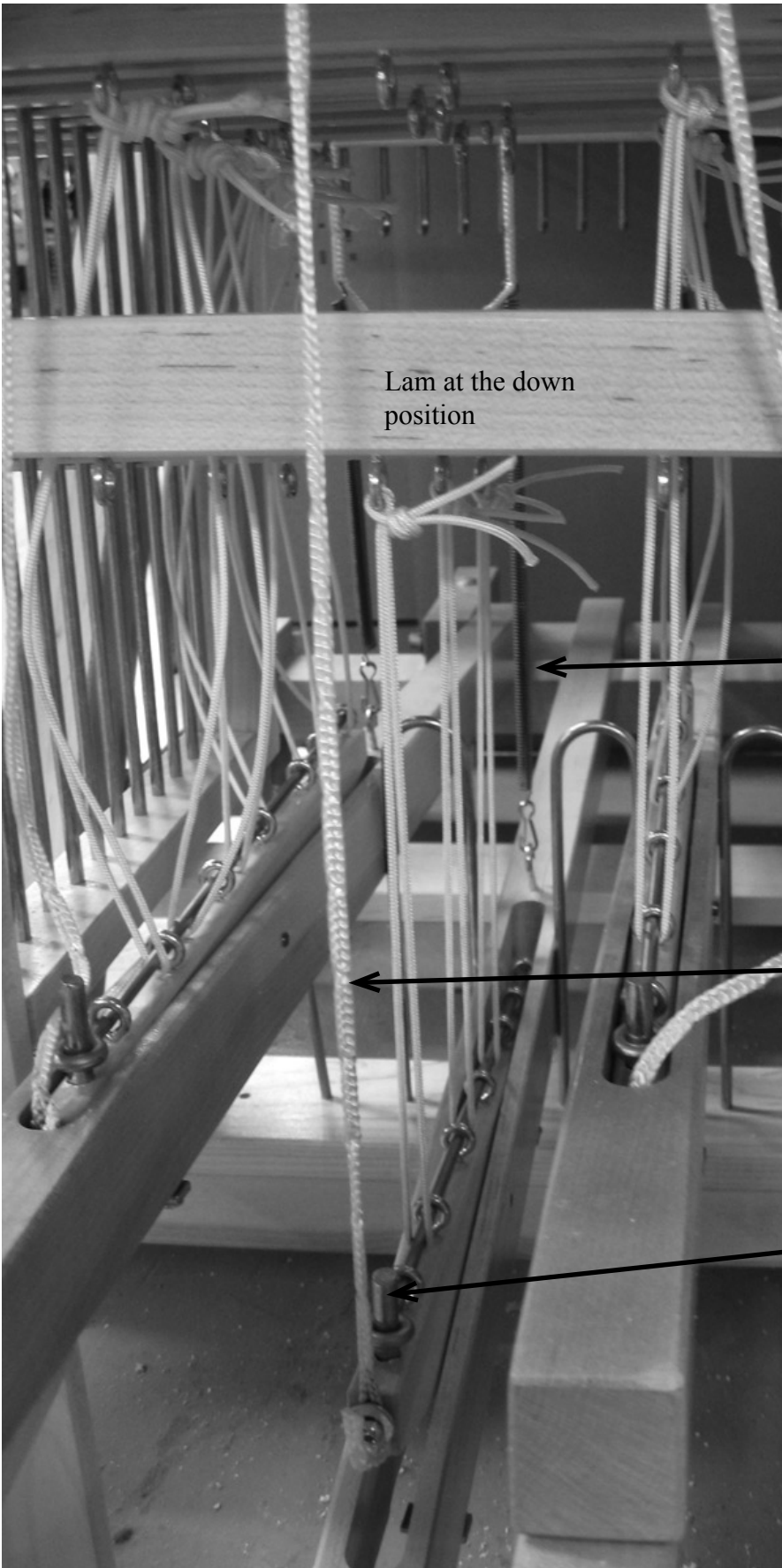

Lam at the down position

FIRST SHED

When you depress the Treadle, the Rocker Loop Cord raises the front of the Rocker setting the Shafts at the correct Level. See next page for more info on adjusting the length of each Rocker loop cord.

Spring under tension when the treadle is down

Rocker loop cord under tension

Treadle hook peg locking the hook in place



View from the back of the loom showing treadle #2 depressed with the treadle spring under tension.



ADJUSTING THE SHED (Length of the Rocker Loop cord)

The key to a wide clean shed is the proper adjustment of the Rocker Loop Cord. Once you have completed the hookup of the Cords and Springs, start at one end of the Treadle Set and depress each Treadle one at a time noting the position of the bottom Shed. Adjust each Shed by shortening or lengthening the Loop Cord. When properly adjusted, the bottom Shed of each Treadle should just kiss the Race Plate and the top Shed should be uniform across the width of the Loom. (see diagrams for examples)

Picture #32 shows an uneven Shed caused by Rocker Loop Cords being out of adjustment.

Picture #33 shows properly adjusted Rocker Loop Cords with the bottom Shed just kissing the Race Plate and the Top Shed uniformly even across the width.

It is very important to maintain a reasonable amount of tension on the Warp when making adjustments and while weaving in order to keep a wide, clean Shed.

The design of the system provides a greater lifting force on the Shafts with considerably less leg pressure required to depress the Treadles. With a few Picks on each new project, the Weaver will find the correct Warp tension required to produce the desired PPI (Picks per Inch) in the Cloth, while maintaining a wide, clean Shed.

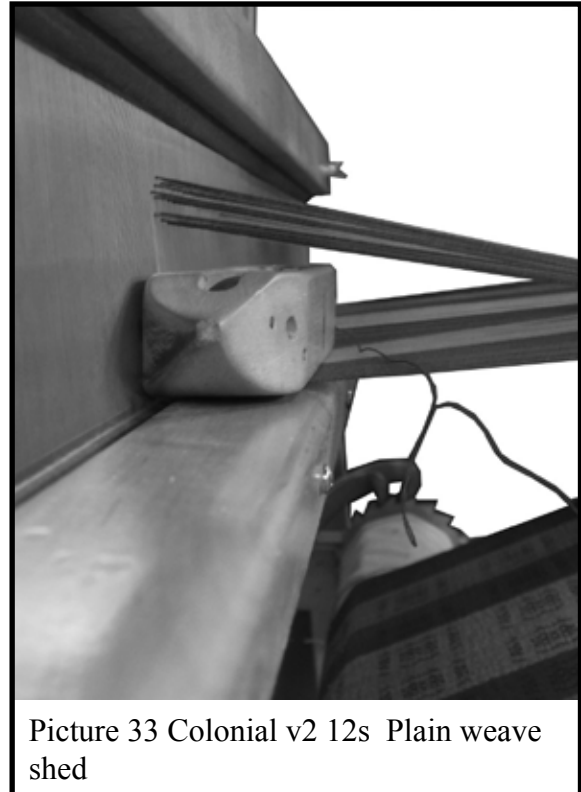
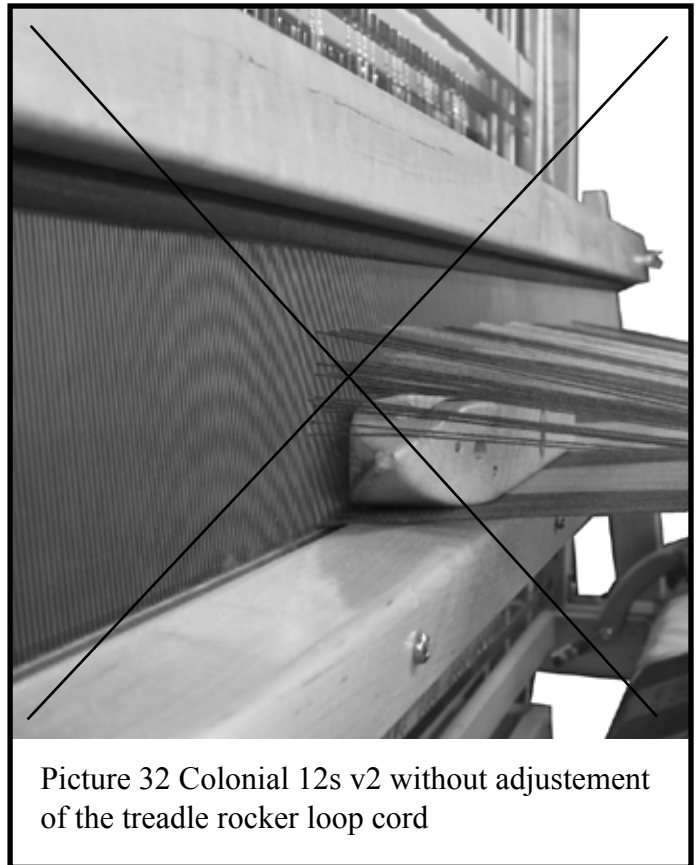

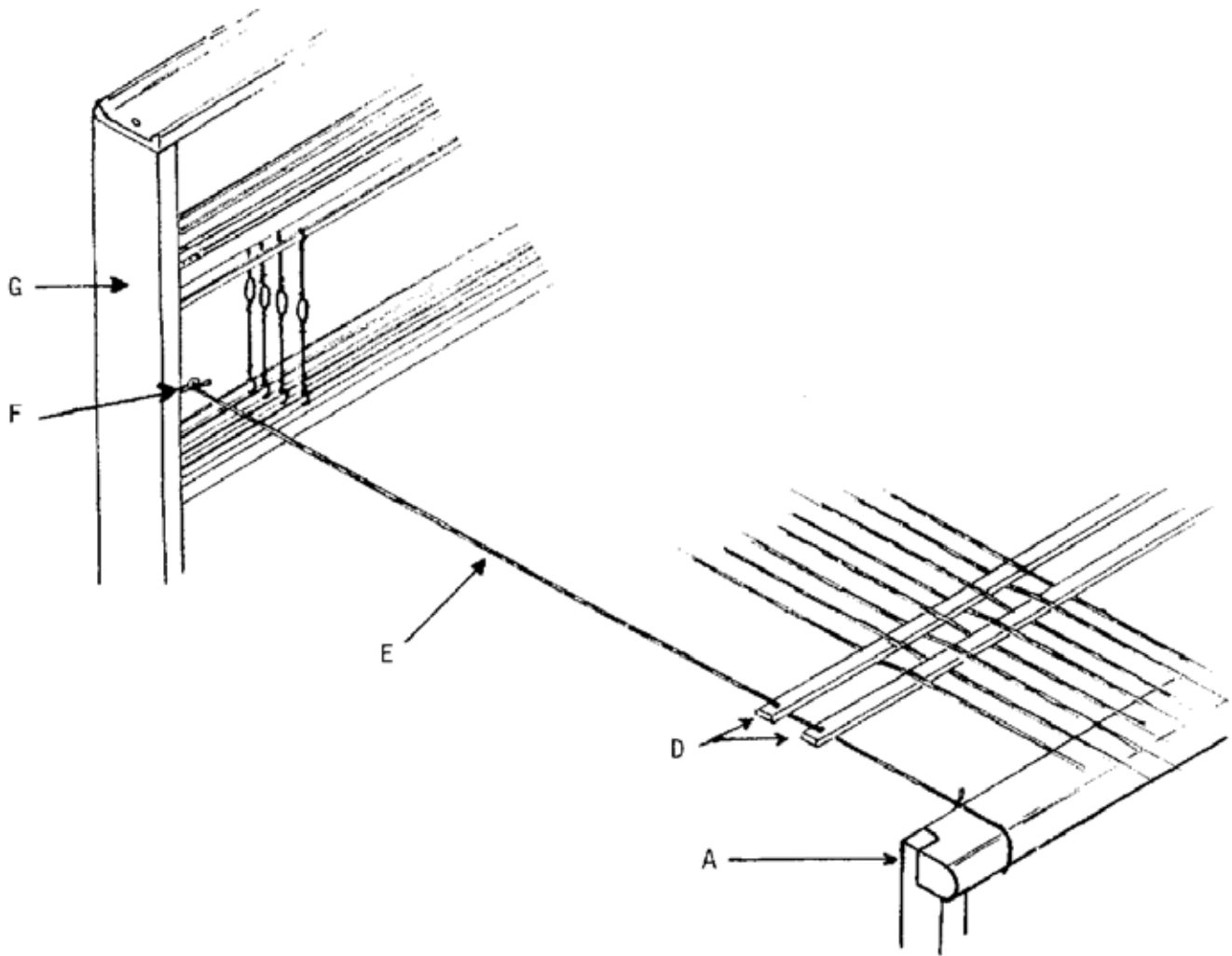

Affix screw eyes F to the holes inside middle posts G.

Pass a string E through the holes at each side of the lease sticks D and tie them to the screw eyes and to the thread beam A. The lease sticks will be held at the right height and distance for easy threading.

If the loom is equipped with a sectional warp beam, affix the rake-like pieces (following the instructions supplied with the sectional warp beam) and do the following instructions on the cloth beam only.

If the loom is not equipped with a sectional warp beam, affix the apron to the warp beam with tacks and do the following procedures on the warp and cloth beams.

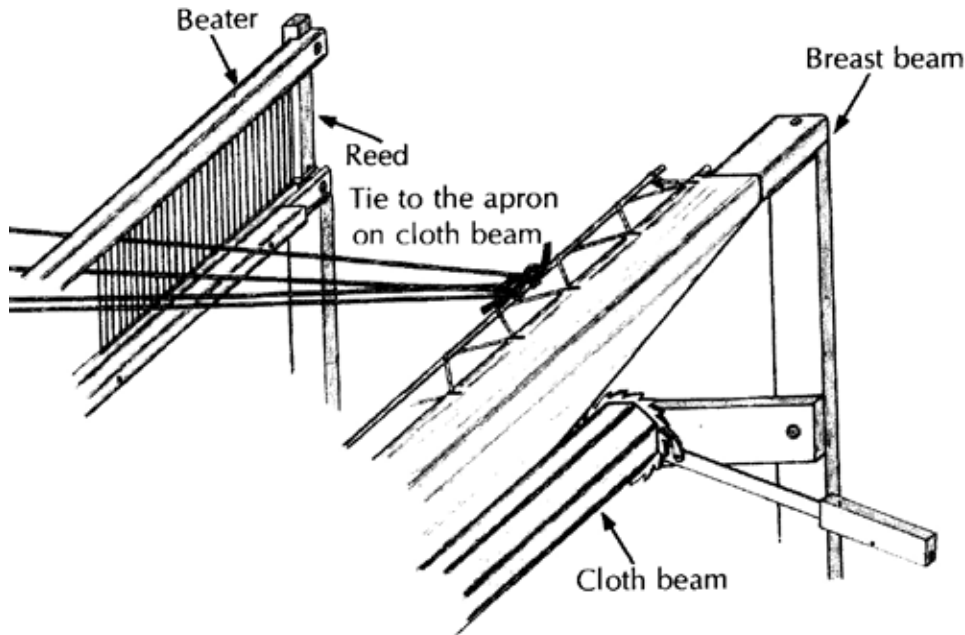

Insert a warp rod into the apron border.

For 27", 36" and 45" loom
(70cm, 90cm and 115cm)

For 60" loom
(150cm)

Cut the 5 yard (4.5m) cord in half.
Use one half of the cord to lace the apron warp rod to a second warp rod. This second warp rod will be used to attach warp threads.

Use a 5 yard (4.5m) cord to lace the apron warp rod to a second warp rod. This second warp rod will be used to attach warp threads.

**We at Leclerc encourage Weaver feedback on
this and all our products. Please
send your comments to Leclerc Loom Co.
info@leclerclooms.com**

HAPPY WEAVING